



# EN KO

Electronic Control Systems



Electronic Control Systems

## ABOUT US

### Establishment & Brief History

ENKO Electronics is an LLC, established in 1982 as an engineering company in order to design and manufacture dedicated electronic control systems for industrial machinery. The company is based in Izmir, a 5000 year old city on the west coastal region of Turkey.

The company moved to its current facilities in the the Ataturk Industrial Zone in 1992. Since then, ENKO recorded a consistent and healthy growth both in sales and production capacity. Several additions were made to the initial factory building in order to keep up with the increasing demand and increase efficiency in our processes.

Today, ENKO has over 120 employees, which over 20 of them are positioned in the ENKO R&D Center, and customer satisfaction is of utmost importance to each and every team member.

### Company Description & Mission

The company sets its mission to achieve intelligent solutions in industrial control systems with both dedicated units for OEM customers and robust universal solutions for all.

In order to achieve this goal, ENKO set its priority to have a fully equipped R&D with the necessary test equipment such as an in-house EMC pre-compliance test lab and other engineering resources. The company management still allocates a significant amount of its profits for its R&D department and today, ENKO works with a valuable design team consisting of hardware, software and test engineers.

To meet rigorous customer requirements, ENKO also employs a well-established Industrial Design team equipped with complete CAD design tools for final modelling.

ENKO's production facilities are furnished with the latest technology production machinery, where radial, axial and SMD components are assembled in full automation. Our board handling systems utilize latest electronic production technology for the most demanding electronic systems production. In-line test and inspection machines can achieve a high standard of reliable production and final quality control.

### Quality Policy

Our main objective is;

To meet the requirements and the expectations of our customers through high quality products and service; of our team members by providing a good working environment and continual education and the society through environmentally-friendly production in compliance with the relevant laws and legislation.

EN  
KO

# AMF-S

## Automatic Mains Failure Control Panels

### Product Description:

AMF-S control panels are designed and manufactured for compact generator applications, where Generator and Mains (Utility) parameters can be configured by the user according to their specific application requirements. AMF-S is the smallest size "Auto Mains Failure Control Module" available on the market.

"S" series AMF Modules provide all necessary control features for "stand-alone" generator applications, and they are equipped with high-resolution 1.4" colour LCD graphical display for easy reading of Generator and Mains data under all environmental conditions. All parameters and system data are displayed in alphanumeric and graphical format. This feature enables easy viewing and understanding of generator status and alarm conditions.

3-phase mains voltage is measured for automatic start of the generator if the mains voltage falls outside set limits. Engine cranking is fully automatic, and all engine parameters are controlled during cranking and running period. 2-phase generator voltage is also measured to control power generation and load management. Load is automatically transferred back to Mains once it is restored with the safe limits.

Monitoring engine speed, coolant temperature and oil pressure continuously provide safe protection and operation of the engine during power generation phase. Also, alternator voltage and frequency are measured for clean power supply to the load. All alarm conditions and warning messages and values are displayed on the graphical display in alpha-numeric and icon formats.

The control module is equipped with suitable digital and analogue inputs and outputs such that, it can be configured for many applications, including stand-by generator applications including lighting tower applications.

Remote start input can be used to integrate the control module with any external control unit.

Integrated CAN bus enables the control module to connect directly to the engine ECU J1939 data bus so that, critical engine data can be read and utilised by the control panel. This feature enables secure connection to all types of engines.

USB Com port is available to configure all the parameters of the control module without connecting the unit to a power source. Unit can be connected to any PC via USB cable and all operation parameters can be configured and saved directly into the control module.

Module front panel is manufactured with silicone rubber keypad for harsh environmental conditions and high IP protection. Plastic frame has built-in sealing gasket to ensure IP65 protection class on the front side of the module.

Unit can operate over a wide range of temperature and humidity conditions. Plug-in type connectors on the back side of the panel reduces the installation and servicing time.

These units also comply to a range of safety and quality standards, which a

### Main Features

- ✓ Smallest size AMF control panel on the market
- ✓ 1.44" Graphical color display for indication of all mains and generator parameters and alarms
- ✓ Automatic transfer of LOAD between Mains and Generator
- ✓ Fully automatic cranking and protection of the engine
- ✓ 8-32Vdc wide range DC power input
- ✓ 3-phase mains voltage reading
- ✓ 2-phase generator voltage reading
- ✓ 3 Analogue inputs
- ✓ 2 Digital inputs
- ✓ 6 Digital solid-state (failsafe) outputs
- ✓ D+ analogue input
- ✓ CAN Bus J1939 com port for connection to engine ECU or peripheral controllers
- ✓ USB2.0 type-B configuration port
- ✓ Plug-in type signal connectors
- ✓ Remote-start function input
- ✓ Silicone rubber keypad with IP65 protection class from the front side, with sealing gasket
- ✓ EMC immunity and emissions compatibility: EN61000-6-2, EN61000-6-4
- ✓ Electrical Safety: EN60950
- ✓ Temperature and Humidity: EN60068-2-30

[info@enkoelektronik.com](mailto:info@enkoelektronik.com)

| Technical Specification  | Value                    | Description                                     |
|--------------------------|--------------------------|---|
| DC Power input voltage:  | 8Vdc to 32Vdc            | Maximum power dissipation is <2.5W              |
| Display:                 | 1.44" LCD Colour graphic | TFT type with high resolution, high brightness  |
| Keypad:                  | Silicone rubber          | UV resistant keypad and enclosure               |
| Mains voltage:           | 3-phase                  | TRUE RMS, high accuracy                         |
| Generator voltage:       | 2-phase                  |   |
| Digital inputs:          | 2 configurable inputs    | Active low input connections (sink type)        |
| Digital outputs:         | 6 digital outputs        | Solid-State (300mA)                             |
| Analogue Inputs:         | 3 analogue sender inputs | Temperature (NTC, KTY) and Pressure (resistive) |
| Charge Alternator Input: | D+ analogue inputs       | Monitors alternator charging status.            |
| Communication ports:     | USB2.0 Type-B            | Parameter configuration                         |
|                          | CAN Bus J1939            | Peripheral control network connection           |
| Operating temperature:   | 10°C to +60°CWide        | Wide Operating range                            |
| Storage temperature:     | 25°C to +85°C            |   |
| Operating humidity:      | 10%RH to 97%RH           | Non-condensing                                  |
| EMC compatibility:       | EN61000-1-2/3/4          | Industrial level                                |
| Safety:                  | CATIII, 300V             | Ensures high-level electrical safety            |
| Vibration & shock:       | MIL810G                  | Transportation                                  |
| Protection class:        | IP65                     | From front side (with gasket)                   |
|                          | IP20                     | From back side                                  |
| Overall dimensions:      | 94 x 82 x 50 mm          | Measurements are in mm                          |
| Panel cutout:            | 80 x 68 mm               |   |
| Mounting type:           | Panel mounting           | With screw type retention clamps                |
| Weight:                  | 140g                     | Approximate weight                              |



Figure 1: AMF-S Front side view

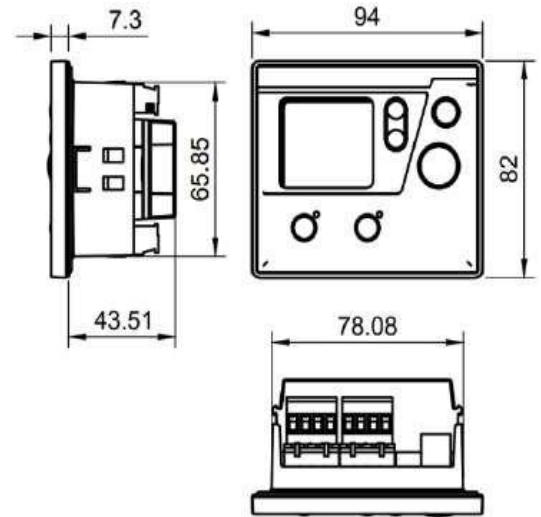
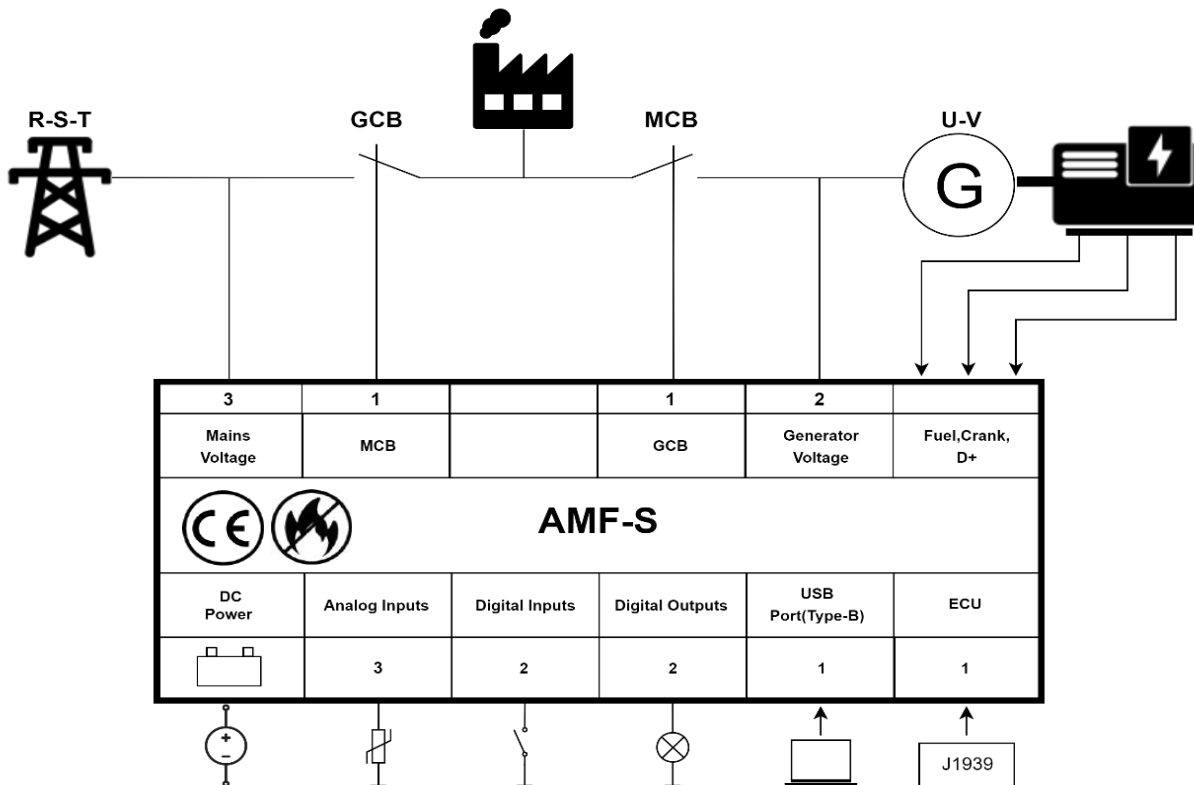

Figure 2: AMF-S Dimensions (mm)

Connection Diagram:



**Compliance:**  
 AMF-S series control panels are tested and compliant to CE regulations for emitted and conducted RFI interference, according to EN61000-6-4 class-A. Immunity is tested against EN61000-6-2. Vibration: EN60068-6-2 Dielectric strength: IEC255, Flammability: UL94, Safety: UL508

# EN KO

COMING  
SOON

GENERATOR  
CONTROL  
MODULES



## AMF-M

### Automatic Mains Failure Control Panels

### Product Description:

AMF-M "Automatic Start Control" units are designed and manufactured for a wide range of generator applications, where comprehensive control functions are required. These modules can monitor and measure an extensive range of engine and alternator parameters and display generator status and alarm warnings on its 2.8" colour graphical display.

These modules can be configured easily via on-board USB port and all system parameters and operating limits can be set in a graphical manner. Specific user parameter data can be stored and uploaded on the factory floor for wide range of custom applications.

"M" series AMF Modules have integrated USB port for system configuration and parameter settings and a CAN J1939 bus for connection to engine ECU to get all engine data during operation. If MPU input is used for engine speed sensing, then CAN Bus can be used for interfacing to other peripheral devices.

3-phase Mains and 3-phase Generator voltages are measured for automatic start of the generator if the mains voltage falls outside set limits. Engine cranking is fully automatic, and all engine parameters are controlled during cranking and running period. Load is automatically transferred back to Mains once it is restored within the safe limits.

Remote start input is also available to control the genset operation from an external remote point. All auto start and engine protection functions are active during remote start operation.

Monitoring engine speed, coolant temperature and oil pressure continuously provide safe protection and operation of the engine during power generation phase. Using integrated hours counter makes it easy for service and maintenance of the generator.

AMF-M control module measures 3-phase generator load current for precise control of the load side during operation. Extensive protection functions can be used to monitor and/or protect the generator during operation. A wide range of AC bus parameters are measured, including KW, kvar, kVA, pF actions can be programmed based on measured values.

Licence-free PC Tools S/W package is available for the customer to set up device configuration via USB port connection. Multi-level password protection allows safe servicing in the field.

Module front panel is manufactured with silicone rubber keypad for harsh environmental conditions and high IP protection. Plastic frame has built-in sealing gasket to ensure IP65 protection class on the front side of the module.

Unit can operate over a wide range of temperature and humidity conditions. Plug-in type connectors on the back side of the panel reduces the installation and servicing time.

### Main Features

- ✓ 2.8" Color graphic display
- ✓ Alphanumeric and graphical presentation of all variables and alarm warnings
- ✓ Multiple language selection from menu
- ✓ Automatic transfer of LOAD between Mains and Generator
- ✓ 3-phase Mains voltage measurement
- ✓ 3-phase Generator voltage measurement
- ✓ 3-phase Generator load current
- ✓ Fully automatic cranking and protection of the engine
- ✓ 3 Analogue sender signal inputs
- ✓ 6 Configurable Digital signal inputs
- ✓ 6 Digital outputs (Solid state)
- ✓ Magnetic Pick-up sensor input
- ✓ D+/WL sensing input
- ✓ RS485 Mod-Bus RTU com port
- ✓ CAN Bus J1939 com port for connection to engine ECU or peripheral controllers
- ✓ USB2.0 type-C configuration port
- ✓ Built-in buzzer feature
- ✓ Plug-in type signal connectors
- ✓ Remote-start function input
- ✓ Hours counter for easy maintenance
- ✓ Alarms & Events log memory
- ✓ Silicone rubber keypad with IP65 protection class from the front side, with sealing gasket
- ✓ EMC immunity and emissions compatibility: EN61000-6-2, EN61000-6-4
- ✓ Electrical Safety: EN60950
- ✓ Temperature and Humidity: EN60068-2-30

[info@enkoelektronik.com](mailto:info@enkoelektronik.com)

| Technical Specification  | Value                    | Description  |
|--------------------------|--------------------------|--|
| DC Power input voltage:  | 8Vdc to 32Vdc            | Maximum power dissipation is <2.5W   |
| Display:                 | 2.8" LCD Colour graphic  | TFT type with high resolution, high brightness                             |
| Keypad:                  | Silicone rubber          | UV resistant keypad and enclosure  |
| Mains voltage :          | 3+1 phase                | TRUE RMS, high accuracy  |
| Generatör voltage:       | 3+1 phase                |  |
| Load current:            | 3-phase load current     |  |
| Digital inputs:          | 6 configurable inputs    | Active low input connections (sink type)                                   |
| Digital outputs:         | 6 digital outputs        | Solid-State fail-safe outputs (1A)   |
| Analogue Inputs:         | 3 analogue sender inputs | Temperature (NTC, KTY) and Pressure For 1-input 4-20mA/0-5V (resistive)    |
| Charge Alternator Input: | (D+WL) analogue inputs   | Monitors alternator charging status.                                       |
| Magnetic pick-up input   | 1 Input                  | MPU connection for speed detection   |
| Buzzer:                  | Available                | Integrated buzzer for alerts   |
| Real-Time Clock (RTC)    | Available                | Integrated real-time clock for scheduled maintenance and fault log records |
| Communication ports:     | USB2.0 Type-C            | Parameter configuration  |
|                          | CAN Bus J1939            | Peripheral control network connection                                      |
|                          | RS485 port               | Modbus RTU   |
| Operating temperature:   | 10°C to +60°CWide        | Wide Operating range   |
| Storage temperature:     | 25°C to +85°C            |  |
| Operating humidity:      | 10%RH to 97%RH           | Non-condensing   |
| EMC compatibility:       | EN61000-1-2/3/4          | Industrial level   |
| Safety:                  | CATIII, 300V             | Ensures high-level electrical safety                                       |
| Vibration & shock:       | MIL810G                  | Transportation   |
| Protection class:        | IP65                     | From front side (with gasket)  |
|                          | IP20                     | From back side   |
| Overall dimensions:      | 165 x 129 x 45 mm        | Measurements are in mm   |
| Panel cutout:            | 151 x 113 mm             |  |
| Mounting type:           | Panel mounting           | With screw type retention clamps   |
| Weight:                  | 180g                     | Approximate weight   |



Figure 1: AMF-M Front side view

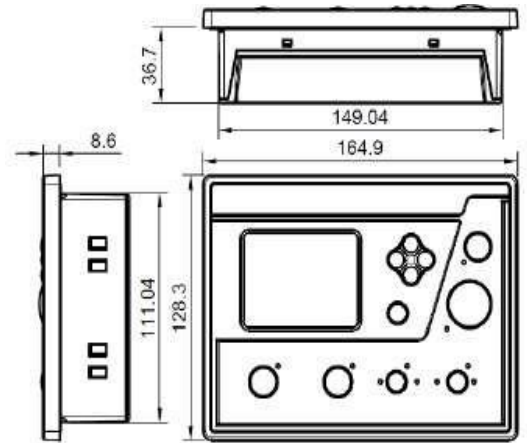
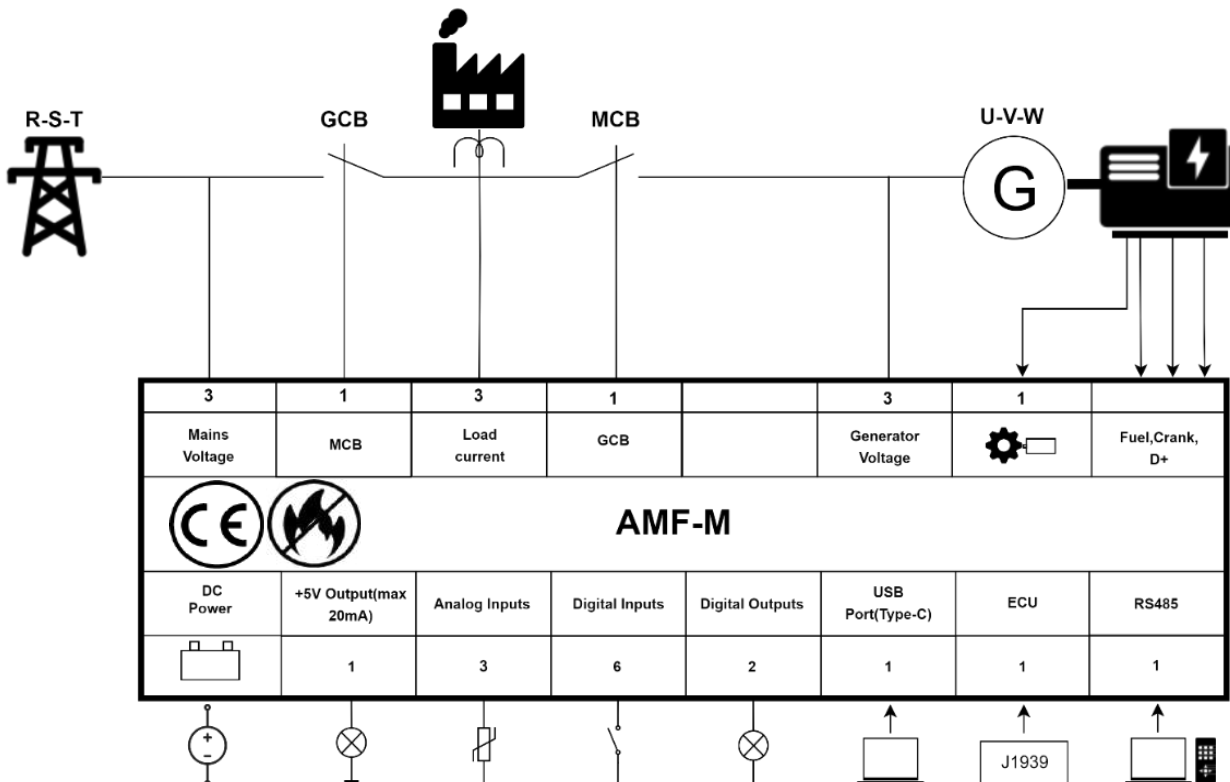

Figure 2: AMF-M Dimensions (mm)

Connection Diagram and System configuration :



Compliance:

AMF-M series control panels are tested and compliant to CE regulations for emitted and conducted RFI interference, according to EN61000-6-4 class-A. Immunity is tested against EN61000-6-2. Vibration: EN60068-6-2 Dielectric strength: IEC255, Flammability: UL94, Safety: UL508

EN  
KO

# AMF-L

## Automatic Mains Failure Control Panels

### Product Description:

AMF-L "Automatic Start Control" units are designed and manufactured for a wide range of generator applications, where comprehensive control functions are required. These modules can monitor and measure an extensive range of engine and alternator parameters and display generator status and alarm warnings on its 2.8" colour graphical display.

These modules can be configured easily via on-board USB port and all system parameters and operating limits can be set in a graphical manner. Specific user parameter data can be stored and uploaded on the factory floor for wide range of custom applications.

"L" series AMF Modules offers flexible communication features for almost every customer demand. USB port is used for system configuration and parameter settings of the AMF module, while CAN J1939 bus can be connected directly to engine ECU to get all engine data during operation. If the user wants to connect the module to external intelligent devices like PLC system, RS485 Mod-BUS RTU can be used to control complete module behaviour during operation. If there is a modem or LAN device available, the AMF module can be connected directly to the network, using ETHERNET com port.

3-phase Mains and 3-phase Generator voltage is measured for automatic start of the generator if the mains voltage falls outside set limits. Engine cranking is fully automatic, and all engine parameters are controlled during cranking and running period. Load is automatically transferred back to Mains once it is restored within the safe limits.

Monitoring engine speed, coolant temperature and oil pressure continuously provide safe protection and operation of the engine during power generation phase. Using integrated hours counter makes it easy for service and maintenance of the generator. Multi-level time scheduling and warning is possible for comprehensive service management in the field.

AMF-L control module measures 3-phase generator load current for precise control of the load side during operation. Extensive protection functions can be used to monitor and/or protect the generator during operation. A wide range of AC bus parameters are measured, including KW, kvar, kVA, pF actions can be programmed based on measured values.

Remote start input can be used to integrate the control module with any external control unit.

Licence-free PC Tools S/W package is available for the customer to set up device configuration via USB port connection. Multi-level password protection allows safe servicing in the field.

Module front panel is manufactured with silicone rubber keypad for harsh environmental conditions and high IP protection. Plastic frame has built-in sealing gasket to ensure IP65 protection class on the front side of the module.

Unit can operate over a wide range of temperature and humidity conditions. Plug-in type connectors on the back side of the panel reduces the installation and servicing time.

### Main Features

- ✓ 2.8" Color graphic display
- ✓ Alphanumeric and graphical presentation of all variables and alarm warnings
- ✓ Multiple language selection from menu
- ✓ Automatic transfer of LOAD between Mains and Generator
- ✓ 3-phase Mains and measurement
- ✓ 3-phase Generator voltage measurement
- ✓ 3-phase Generator load current
- ✓ Fully automatic cranking and protection of the engine
- ✓ 3 Analogue signal inputs
- ✓ 7 Digital signal inputs
- ✓ 8 Digital outputs (4 relay, 4 Solid state)
- ✓ Magnetic Pick-up sensor input
- ✓ D+/WL sensing input
- ✓ 8-32Vdc wide range DC power input
- ✓ CAN Bus J1939 com port for connection to engine ECU or peripheral controllers
- ✓ USB2.0 type-B configuration port
- ✓ RS485 Mod-Bus RTU com port
- ✓ ETHERNET communication port
- ✓ Plug-in type signal connectors
- ✓ Remote-start function input
- ✓ Hours counter for easy maintenance
- ✓ Alarms & Events log memory
- ✓ Silicone rubber keypad with IP65 protection class from the front side, with sealing gasket
- ✓ EMC immunity and emissions compatibility: EN61000-6-2, EN61000-6-4
- ✓ Electrical Safety: EN60950
- ✓ Temperature and Humidity: EN60068-2-30

[info@enkoelektronik.com](mailto:info@enkoelektronik.com)

| Technical Specification  | Value                    | Description  |
|--------------------------|--------------------------|--|
| DC Power input voltage:  | 8Vdc to 32Vdc            | Maximum power dissipation is <2.5W   |
| Display:                 | 2.8" LCD Colour graphic  | TFT type with high resolution, high brightness                             |
| Keypad:                  | Silicone rubber          | UV resistant keypad and enclosure  |
| Mains voltage :          | 3+1 phase                | TRUE RMS, high accuracy  |
| Generatör voltage:       | 3+1 phase                |  |
| Load current:            | 3-phase load current     |  |
| Digital inputs:          | 2 configurable inputs    | Active low input connections (sink type)                                   |
| Digital outputs:         | 8 digital outputs        | 4 Relay (3A) + 4 Solid-State (500mA)                                       |
| Analogue Inputs:         | 4 analogue sender inputs | Temperature (NTC, KTY) and Pressure (resistive)                            |
| Analogue Outputs:        | 1 analogue output        | For AVR (Available in AMF-L Military version)                              |
| Charge Alternator Input: | (D+WL) analogue inputs   | Monitors alternator charging status.                                       |
| Magnetic pick-up input   | 1 Input                  | MPU connection for speed detection   |
| Real-Time Clock (RTC)    | Available                | Integrated real-time clock for scheduled maintenance and fault log records |
| Communication ports:     | USB2.0 Type-B            | Parameter configuration  |
|                          | CAN Bus J1939            | Peripheral control network connection                                      |
|                          | RS485 port               | Modbus RTU   |
|                          | Ethernet Port            | For network and modem connection   |
| Operating temperature:   | 10°C to +60°CWide        | Wide Operating range   |
| Storage temperature:     | 25°C to +85°C            |  |
| Operating humidity:      | 10%RH to 97%RH           | Non-condensing   |
| EMC compatibility:       | EN61000-1-2/3/4          | Industrial level   |
| Safety:                  | CATIII, 300V             | Ensures high-level electrical safety                                       |
| Vibration & shock:       | MIL810G                  | Transportation   |
| Protection class:        | IP65                     | From front side (with gasket)  |
|                          | IP20                     | From back side   |
| Overall dimensions:      | 205 x 158 x 45 mm        | Measurements are in mm   |
| Panel cutout:            | 182 x 135 mm             |  |
| Mounting type:           | Panel mounting           | With screw type retention clamps   |
| Weight:                  | 220g                     | Approximate weight   |



Figure 1: AMF-L Front side view

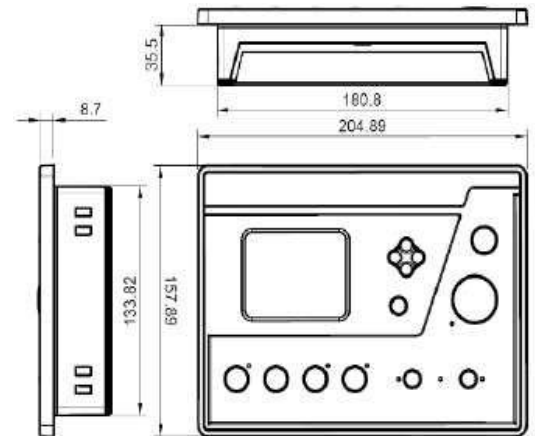
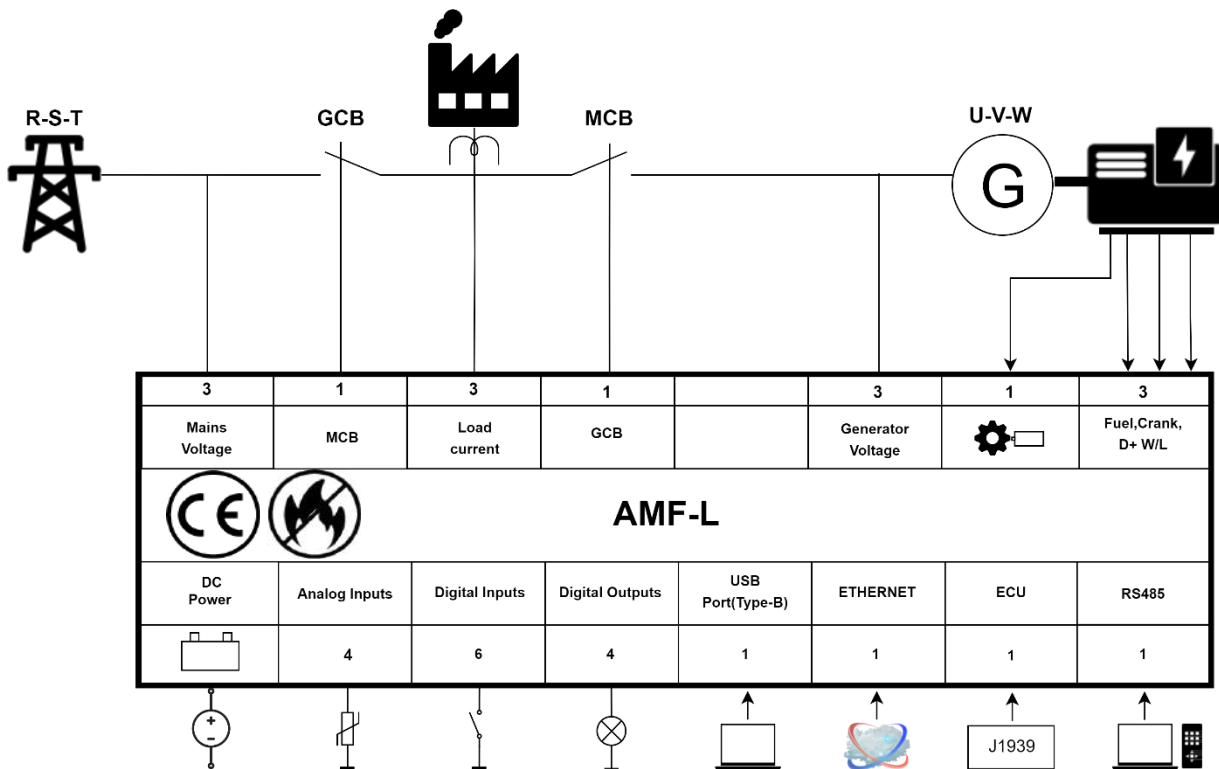

Figure 2: AMF-L Dimensions (mm)

Connection Diagram and System configuration :



Compliance:

AMF-L series control panels are tested and compliant to CE regulations for emitted and conducted RFI interference, according to EN61000-6-4 class-A. Immunity is tested against EN61000-6-2. Vibration: EN60068-6-2 Dielectric strength: IEC255, Flammability: UL94, Safety: UL508

# EN KO

COMING  
SOON

GENERATOR  
CONTROL  
MODULES

## AMF-L PRO

### Automatic Mains Failure Control Panels

*“No-Break Load Transition”  
between Mains & Generator*



## Product Description:

**AMF-L PRO** “AUTO START CONTROL” units are designed for demanding generator applications, where comprehensive control features are required. These modules can monitor and measure an extensive range of engine and alternator parameters and display generator status and alarm warnings on its 4.3” colour graphical display.

These modules can be configured easily via on-board USB port and all system parameters and operating limits can be set in a graphical manner. Specific user parameter data can be stored and uploaded on the factory floor for wide range of custom applications.

**PRO** series control panels can adjust the GENERATOR bus voltage against MAINS bus such that, no-break load transition can be achieved with **built-in “synchronoscope”** function. Built-in second CAN J1939 bus can be connected directly to engine ECU and/or to the GOVERNOR unit for easy management of engine parameters.

“**PRO**” series AMF Modules offers flexible communication features for almost every customer demand. USB port is used for system configuration and parameter settings of the AMF module, while one of the remaining CAN port can be connected to peripheral devices. If the user wants to connect the module to external intelligent devices like PLC system, RS485 Mod-BUS RTU can be used to control complete module behaviour during operation. If there is a modem or LAN device available, the AMF module can be connected directly to the network, using ETHERNET com port.

3-phase Mains and 3-phase Generator voltage is measured for automatic start of the generator if the mains voltage falls outside set limits. Engine cranking is fully automatic, and all engine parameters are controlled during cranking and running period. Load is automatically transferred back to Mains once it is restored within the safe limits.

Monitoring engine speed, coolant temperature and oil pressure continuously provide safe protection and operation of the engine during power generation phase. Using integrated hours counter makes it easy for service and maintenance of the generator. Multi-level time scheduling and warning is possible for comprehensive service management in the field.

**AMF-L PRO** control module measures 3-phase generator load current for precise control of the GENERATOR during operation. Extensive protection functions can be used to monitor and/or protect the generator during operation. Neutral current is also measured for unbalanced bus protection. A wide range of AC bus parameters are measured, including KW, kvar, kVA, pF actions can be programmed based on measured values.

For multiple-generator applications, **AMF-L PRO** unit can monitor operation times and with its built-in **“Equal-Aging”** feature, units can automatically equalize generator running times, based on their availability on the AC BUS. For this feature, no additional control devices are required.

Remote start input can be used to integrate the control module with any external control unit.

Licence-free PC Tools S/W package is available for the customer to set up device configuration via USB port connection. Multi-level password protection allows safe servicing in the field.

Module front panel is manufactured with silicone rubber keypad for harsh environmental conditions and high IP protection. Plastic frame has built-in sealing gasket to ensure IP65 protection class on the front side of the module.

Unit can operate over a wide range of temperature and humidity conditions. Plug-in type connectors on the back side of the panel reduces the installation and servicing time.

### Main Features

- ✓ 4.3” Color graphic display
- ✓ Alphanumeric and graphical presentation of all variables and alarm warnings
- ✓ Multiple language selection from menu
- ✓ Automatic transfer of LOAD between Mains and Generator
- ✓ 3-phase Mains measurement
- ✓ 3-phase Generator voltage measurement
- ✓ 3-phase Generator load current
- ✓ 1 earth current
- ✓ NEUTRAL current measurement
- ✓ Fully automatic cranking and protection of the engine
- ✓ 4 Analogue sender signal inputs
- ✓ 2 Analogue output for AVR control and Governor control
- ✓ 7 Digital signal inputs
- ✓ 10 Digital outputs (4 relay, 4 Solid state)
- ✓ Magnetic Pick-up sensor input
- ✓ D+/WL sensing input
- ✓ 8-32Vdc wide range DC power input
- ✓ 2xCAN Bus J1939 com port for connection to engine ECU or peripheral controllers
- ✓ USB2.0 type-C configuration port
- ✓ RS485 Mod-Bus RTU com port
- ✓ ETHERNET communication port
- ✓ Plug-in type signal connectors
- ✓ Remote-start function input
- ✓ Built-in “SYNCHROSCOPE” function
- ✓ Hours counter for easy maintenance
- ✓ Alarms & Events log memory
- ✓ Silicone rubber keypad with IP65 protection class from the front side, with sealing gasket
- ✓ EMC immunity and emissions compatibility: EN61000-6-2, EN61000-6-4
- ✓ Electrical Safety: EN60950
- ✓ Temperature and Humidity: EN60068-2-30

[info@enkoelektronik.com](mailto:info@enkoelektronik.com)

| Technical Specification  | Value                    | Description  |
|--------------------------|--------------------------|--|
| DC Power input voltage:  | 8Vdc to 32Vdc            | Maximum power dissipation is <2.5W   |
| Display:                 | 4.3" LCD Colour graphic  | TFT type with high resolution, high brightness                             |
| Keypad:                  | Silicone rubber          | UV resistant keypad and enclosure  |
| Mains voltage :          | 3+1 phase                | TRUE RMS, high accuracy  |
| Generatör voltage:       | 3+1 phase                |  |
| Load current:            | 3-phase load current     |  |
| Digital inputs:          | 2 configurable inputs    | Active low input connections (sink type)                                   |
| Digital outputs:         | 10 digital outputs       | 6 Röle (3A) + 4 Solid-State (500mA)  |
| Analogue Inputs:         | 4 analogue sender inputs | Temperature (NTC, KTY) and Pressure (resistive)                            |
| Analogue Outputs:        | 1 analogue outputs       | For AVR and GOV control  |
| Charge Alternator Input: | (D+WL) analogue inputs   | Monitors alternator charging status.                                       |
| Magnetic pick-up input   | 1 Input                  | MPU connection for speed detection   |
| Real-Time Clock (RTC)    | Available                | Integrated real-time clock for scheduled maintenance and fault log records |
| Communication ports:     | USB2.0 Type-B            | Parameter configuration  |
|                          | CAN Bus J1939            | Peripheral control network connection                                      |
|                          | RS485 port               | Modbus RTU   |
|                          | Ethernet Port            | For network and modem connection   |
| Operating temperature:   | 10°C to +60°CWide        | Wide Operating range   |
| Storage temperature:     | 25°C to +85°C            |  |
| Operating humidity:      | 10%RH to 97%RH           | Non-condensing   |
| EMC compatibility:       | EN61000-1-2/3/4          | Industrial level   |
| Safety:                  | CATIII, 300V             | Ensures high-level electrical safety                                       |
| Vibration & shock:       | MIL810G                  | Transportation   |
| Protection class:        | IP65                     | From front side (with gasket)  |
|                          | IP20                     | From back side   |
| Overall dimensions:      | 205 x 158 x 45 mm        | Measurements are in mm   |
| Panel cutout:            | 182 x 135 mm             |  |
| Mounting type:           | Panel mounting           | With screw type retention clamps   |
| Weight:                  | 220g                     | Approximate weight   |



Figure 1: AMF-L PRO Front side view

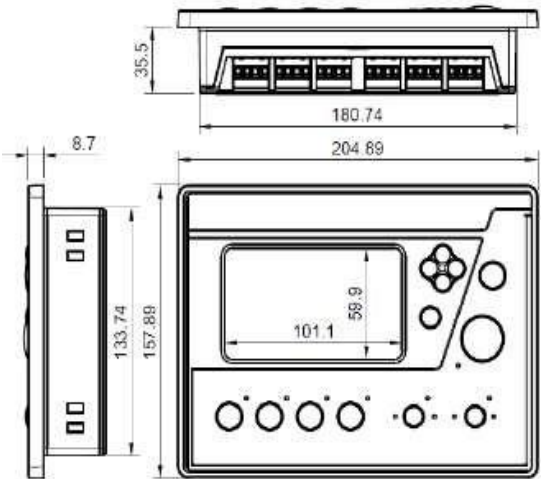
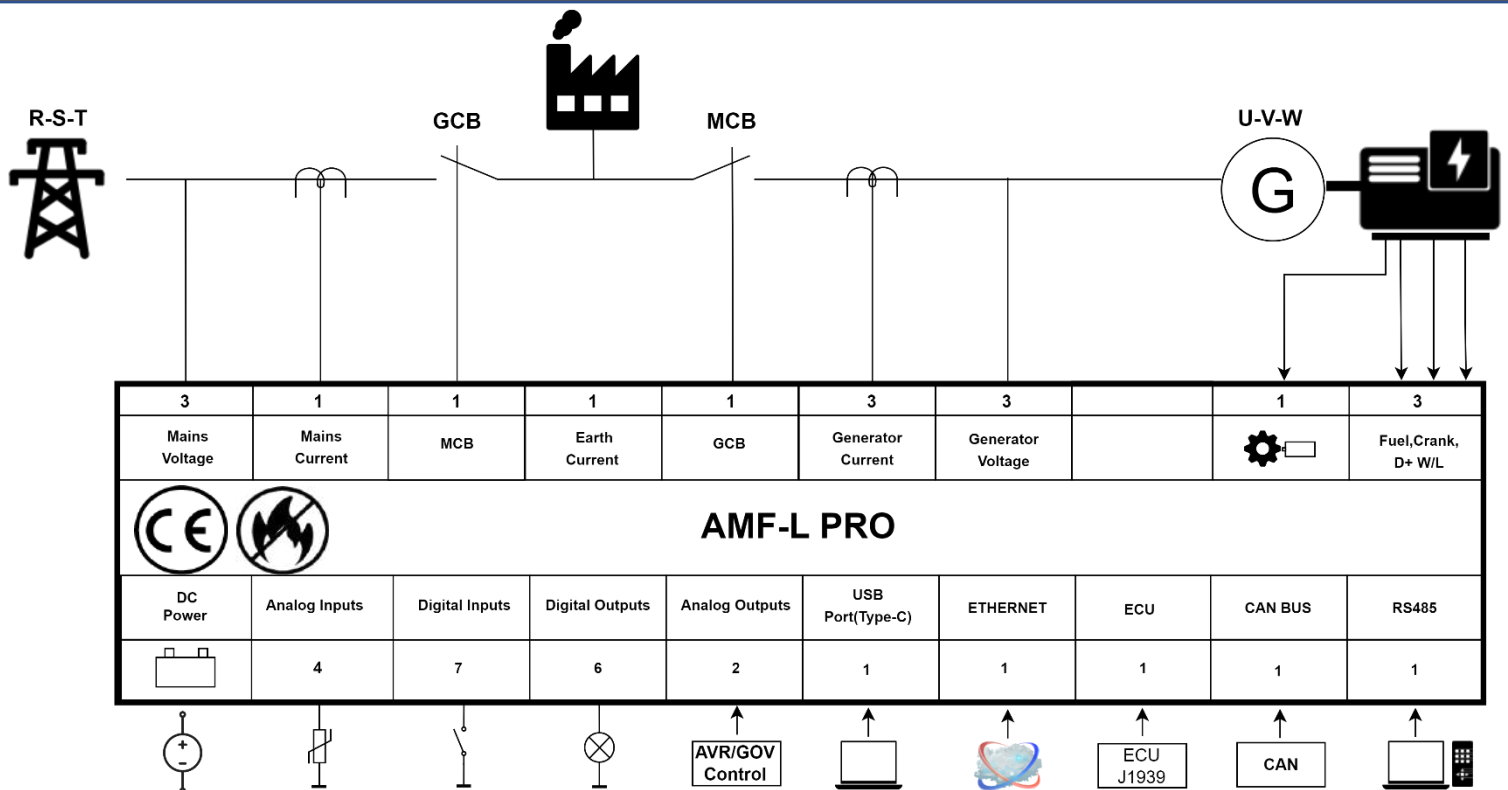

Figure 2: AMF-L PRO Dimensions

Connection Diagram and System configuration :



Compliance:

AMF-L PRO series control panels are tested and compliant to CE regulations for emitted and conducted RFI interference, according to EN61000-6-4 class-A. Immunity is tested against EN61000-6-2. Vibration: EN60068-6-2 Dielectric strength: IEC255, Flammability: UL94, Safety: UL508

EN  
KO

# ESU-S

## Engine Start Unit

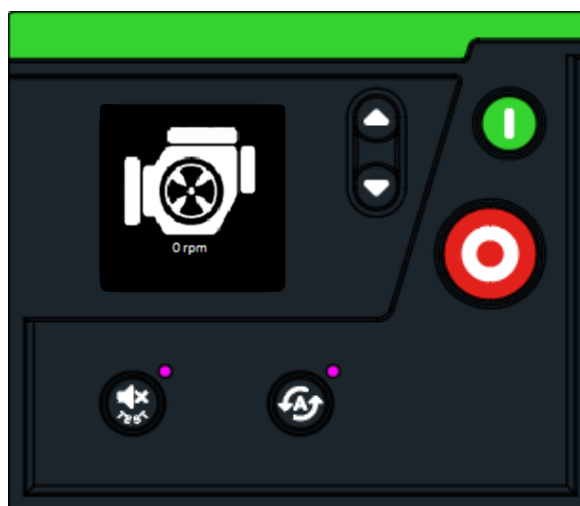

## Product Description:

ESU-S control panel is designed for intelligent and safe control of diesel and gasoline engines for a wide range of applications. These control units can be used for power generation applications as well as for a wide range of industrial applications, which desires an engine as prime mover.

ESU-S has 3 different types of operating scenarios. These are Manual Generator (no mains) pump and fire pump. With these 3 operating modes that can be easily selected from the menu, it allows the use of a single product for different applications.

The built-in real-time clock enables scheduled operations without the need for additional hardware.

A single-button crank function ensures safe engine start, with full protection during both cranking and running. Engine speed is precisely monitored via a magnetic pick-up input. For flexible integration, a D+/WL connection supports various engine types, while the CAN J1939 interface allows secure monitoring and control of ECU-equipped engines.

Oil pressure, coolant temperature and fuel level are measured with analogue inputs and all measured values are displayed on integrated 1.4" colour graphical screen with high visibility, even under strong environment light conditions..

For integration with generator, ESU-S control panel is also equipped with 2-phase generator voltage measurement inputs and an output to control the GCB. For remote start applications, an external "Remote Start" input is also available to initiate cranking and an output to control the GCB switchgear

The unit can be configured via the built-in USB2 port using the licence-free PC-Tools software to set or read system parameters.

The units also have additional spare inputs and outputs to control peripheral equipment, if necessary. All auxiliary i/o ports can be configured by the user according to application.

Module front panel is manufactured with silicone rubber keypad for harsh environmental conditions and high IP protection. Plastic frame has built-in sealing gasket to ensure IP65 protection class on the front side of the module.

Unit can operate over a wide range of temperature and humidity conditions. Plug-in type connectors on the back side of the panel reduces the installation and servicing time.

All units comply to CE standards for EMC directives and safety against UL94.

## Main Features

- ✓ Smallest size ESU control panel on the market
- ✓ 1.4" Graphical color display for indication of all engine and generator parameters and alarms
- ✓ Scheduled operation with built-in real time clock.
- ✓ Built-in operating modes
  - Manual generator
  - Pump
  - Fire Pump
- ✓ Automatic LOAD connection (MCB)
- ✓ Fully automatic cranking and protection of the engine
- ✓ 2-phase generator voltage reading
- ✓ 3 Analogue inputs
- ✓ D+/WL analogue input
- ✓ 3 Digital inputs
- ✓ 6 Digital solid-state (failsafe) outputs
- ✓ 8-32Vdc wide range DC power input
- ✓ CAN Bus J1939 com port for connection to engine ECU or peripheral controllers
- ✓ USB2.0 type-B configuration port
- ✓ Plug-in type signal connectors
- ✓ Remote-start function input
- ✓ Fire Pump / Prime Power function selection option
- ✓ Silicone rubber keypad with IP65

| Technical Specification  | Value                    | Description  |
|--------------------------|--------------------------|--|
| DC Power input voltage:  | 8Vdc to 32Vdc            | Maximum power dissipation is <2.5W   |
| Display:                 | 1.44" LCD Colour graphic | TFT type with high resolution, high brightness                             |
| Keypad:                  | Silicone rubber          | UV resistant keypad and enclosure  |
| Generator voltage:       | 2-phase                  | TRUE RMS, high accuracy  |
| Digital inputs:          | 4 configurable inputs    | Active low input connections (sink type)                                   |
| Digital outputs:         | 6 digital outputs        | Solid-State (300mA)  |
| Analogue Inputs:         | 3 analogue sender inputs | Temperature (NTC, KTY) and Pressure (resistive)                            |
| Real-Time Clock (RTC)    | Available                | Integrated real-time clock for scheduled maintenance and fault log records |
| Magnetic pick-up input   | 1 Input                  | MPU connection for speed detection   |
| Charge Alternator Input: | D+ analogue inputs       | Monitors alternator charging status.                                       |
| Communication ports:     | USB2.0 Type-B            | Parameter configuration  |
|                          | ECU J1939                | Peripheral control network connection                                      |
| Operating temperature:   | 10°C to +60°CWide        | Wide Operating range   |
| Storage temperature:     | 25°C to +85°C            |  |
| Operating humidity:      | 10%RH to 97%RH           | Non-condensing   |
| EMC compatibility:       | EN61000-1-2/3/4          | Industrial level   |
| Safety:                  | CATIII, 300V             | Ensures high-level electrical safety                                       |
| Vibration & shock:       | MIL810G                  | Transportation   |
| Protection class:        | IP65                     | From front side (with gasket)  |
|                          | IP20                     | From back side   |
| Overall dimensions:      | 94 x 82 x 50 mm          | Measurements are in mm   |
| Panel cutout:            | 80 x 68 mm               |  |
| Mounting type:           | Panel mounting           | With screw type retention clamps   |
| Weight:                  | 140g                     | Approximate weight   |

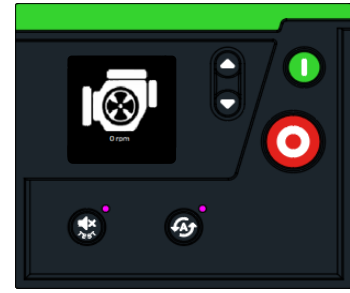

Figure 1: ESU-S Front side view

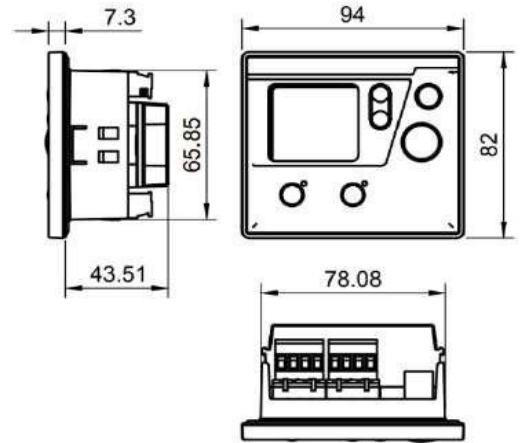
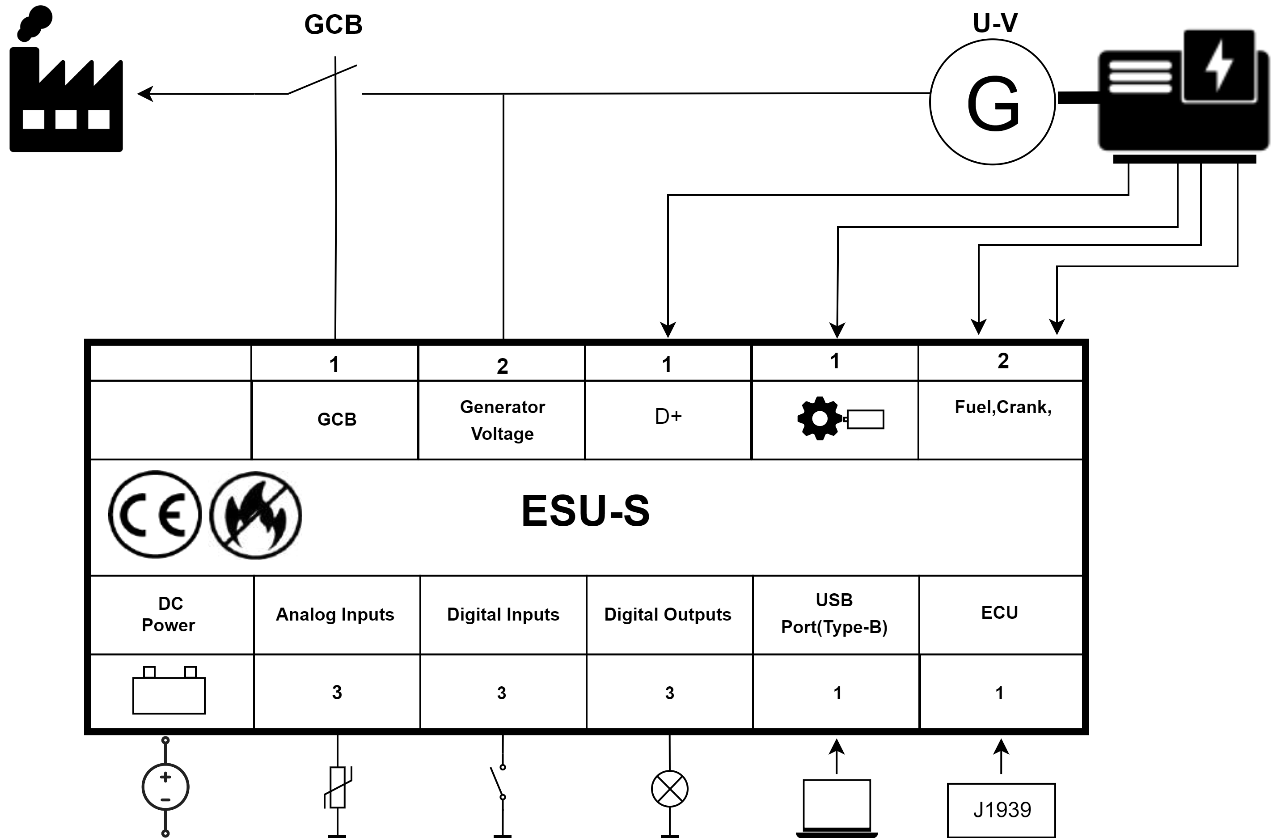

Figure 2: ESU-S Dimensions (mm)

Connection Diagram:



Compliance:  
 ESU-S series control panels are tested and compliant to CE regulations for emitted and conducted RFI interference, according to EN61000-6-4 class-A. Immunity is tested against EN61000-6-2. Vibration: EN60068-6-2 Dielectric strength: IEC255, Flammability: UL94, Safety: UL508

EN  
KO

# ATS-S

## Automatic Transfer Switch Control Unit

### Product Description:

ATS-S "Automatic Transfer Switch" control panel is designed to connect any LOAD between two independent AC supply sources.

The unit monitors 3-phase voltage and frequency from the two incoming independent AC supply sources and can switch the load, depending on which AC source is available.

Load current is also monitored, and various load protection functions can be enabled, depending on application requirements.

If the unit is connected across mains (utility) and a generator, a "Remote Start" signal is generated, based on the programmed parameters, (voltage, frequency, and time delays). Once the second source is established within the healthy limits, the load is automatically switched to generator and at the same time, monitoring both incoming AC sources. When utility is back within the healthy limits, load will be switched back to the mains and remote-start signal will be removed to shut the generator down.

All protection functions are built into the system so that, even generator cool-down timing can be programmed into the unit. This allows even the simplest power generators to be connected safely to the load with mains (Utility) connection.

ATS-S control panel has extensive built-in functions to safely control the load under any circumstances. It allows the user to program switching time delays, start delays and can also allocate certain output

signals to control any peripheral equipment depending on the operation conditions.

The unit is equipped with 6 configurable solid-state outputs and 4 configurable inputs to control the load and the switchgear. Load current can be monitored and if load limit exceeds programmed limits while feeding from generator source, an alarm can be generated, and load can be switched off safely.

The unit has a 1.4" colour LCD display to display all system variables in alphanumeric and graphical formats. The display background changes colour in case an alarm is generated, and it can be seen from long distance.

Built-in USB communication port is used to program the unit directly from a USB connection cable. No external power is needed for configuring the unit.

Module front panel is manufactured with silicone rubber keypad for harsh environmental conditions and high IP protection. Plastic frame has built-in sealing gasket to ensure IP65 protection class on the front side of the module.

Unit can operate over a wide range of temperature and humidity conditions. Plug-in type connectors on the back side of the panel reduces the installation and servicing time.

These units also comply to a wide range of safety and quality standards.

### Main Features

- ✓ Smallest size ATS control panel on the market
- ✓ 1.44" Graphical color display for indication of all mains and generator parameters and alarms
- ✓ Automatic transfer of LOAD between Mains and Generator
- ✓ 1- phase Load current
- ✓ 3-phase mains voltage reading
- ✓ 3-phase generator voltage reading
- ✓ 4 Configurable Digital inputs
- ✓ 6 Configurable Digital solid-state (failsafe) outputs
- ✓ Continuous Load current measurement
- ✓ 8-32Vdc wide range DC power input
- ✓ USB2.0 type-B configuration port
- ✓ Plug-in type signal connectors
- ✓ Remote-start function output
- ✓ Silicone rubber keypad with IP65 protection class from the front side, with sealing gasket
- ✓ EMC immunity and emissions compatibility: EN61000-6-2, EN61000-6-4
- ✓ Electrical Safety: EN60950
- ✓ Temperature and Humidity: EN60068-2-30

[info@enkoelektronik.com](mailto:info@enkoelektronik.com)

| Technical Specification | Value                    | Description                                    |
|-------------------------|--------------------------|--|
| DC Power input voltage: | 8Vdc to 32Vdc            | Maximum power dissipation is <2.5W             |
| Display:                | 1.44" LCD Colour graphic | TFT type with high resolution, high brightness |
| Keypad:                 | Silicone rubber          | UV resistant keypad and enclosure              |
| Mains voltage:          | 3-phase                  | TRUE RMS, high accuracy                        |
| Generator voltage:      | 3-phase                  |  |
| Load current:           | 1-phase                  |  |
| Digital inputs:         | 4 configurable inputs    | Active low input connections (sink type)       |
| Digital outputs:        | 6 digital outputs        | Solid-State (300mA)                            |
| Communication ports:    | USB2.0 Type-B            | Parameter configuration                        |
| Operating temperature:  | 10°C to +60°CWide        | Wide Operating range                           |
| Storage temperature:    | 25°C to +85°C            |  |
| Operating humidity:     | 10%RH to 97%RH           | Non-condensing                                 |
| EMC compatibility:      | EN61000-1-2/3/4          | Industrial level                               |
| Safety:                 | CATIII, 300V             | Ensures high-level electrical safety           |
| Vibration & shock:      | MIL810G                  | Transportation                                 |
| Protection class:       | IP65                     | From front side (with gasket)                  |
|                         | IP20                     | From back side                                 |
| Overall dimensions:     | 94 x 82 x 50 mm          | Measurements are in mm                         |
| Panel cutout:           | 80 x 68 mm               |  |
| Mounting type:          | Panel mounting           | With screw type retention clamps               |
| Weight:                 | 140g                     | Approximate weight                             |



Figure 1: ATS-S Front side view

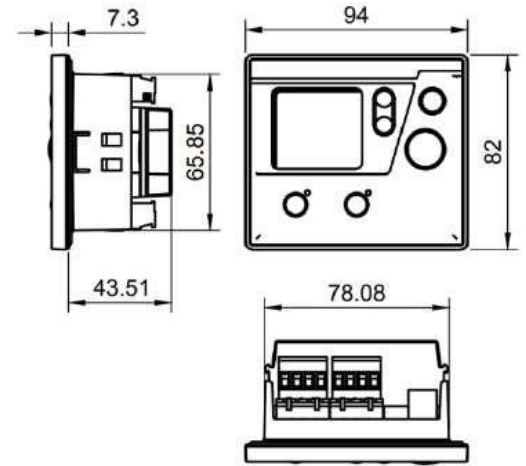
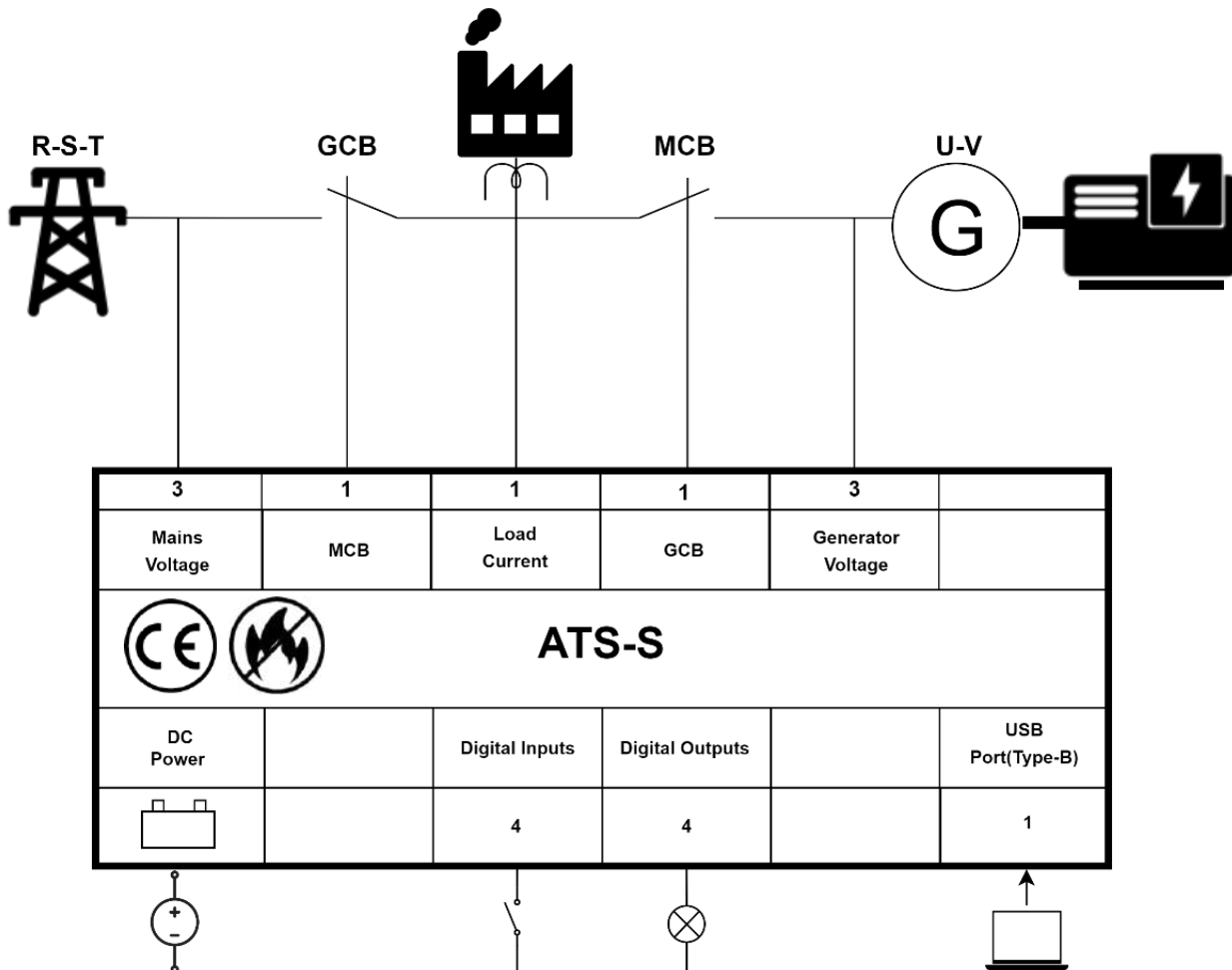

Figure 2: ATS-S Dimensions (mm)

Connection Diagram:



**Compliance:**  
 ATS-S series control panels are tested and compliant to CE regulations for emitted and conducted RFI interference, according to EN61000-6-4 class-A. Immunity is tested against EN61000-6-2. Vibration: EN60068-6-2 Dielectric strength: IEC255, Flammability: UL94, Safety: UL508

EN  
KO

## BC-S



Switching mode Battery Chargers

## Product Description:

BC-S series chargers are based on “switching-mode” design concept with high efficiency and reliability, suitable for all types of Lead-acid batteries.

These chargers are ideal for applications, where a battery needs to be maintained at best performance for starting (cranking) of all types of engines. These chargers have “3-stage Dynamic Charge” characteristics, which ensure to restore battery capacity at maximum level, based on the battery health status.

Based on its switching-mode topology, charger unit has high-efficiency during full range of its charging range. The charging DC current has minimum ripple, which prolongs “battery lifetime” and increases performance. BC-S series chargers are designed to operate at full rating over a very wide range of AC input supply voltage. Therefore, in applications where mains supply widely fluctuates, these chargers perform reliably and restore the battery capacity in the shortest possible time.

BCS90 series chargers are equipped with all necessary protection functions to ensure high-reliability operation under all conditions. Multiple chargers can be connected in parallel to increase capacity or operate in redundant mode.

These chargers can deliver full rated current into short circuit, therefore capable of charging a battery even if it is fully depleted.

## WHAT'S NEW

### Main Features

- ✓ 3-stage Dynamic Charging characteristics
  - Bulk charge
  - Absorption
  - Float
- ✓ 88Vac - 264Vac universal mains voltage input range
- ✓ Efficiency >85%
- ✓ Voltage ripple <0.15V
- ✓ -25°C to +60°C operating
- ✓ Protection above 60°C
- ✓ Short circuit protection (can deliver full rated current into short circuit)
- ✓ Over-voltage protection
- ✓ External BOOST control function
- ✓ Alarm output
- ✓ LED indication for alarm and operation status
- ✓ 4KV galvanic isolation between AC input and DC output
- ✓ Compact design with DIN Rail mounting or panel-mount
- ✓ CE compliance tests:
  - EN61000-6-2/4
  - EN61000-4-2/4/5/11
  - UL94 flammability compliance

[info@enkoelektronik.com](mailto:info@enkoelektronik.com)

| Technical Specifications                 | Description  |          |          |
|--|--|----------|----------|
| AC Supply input voltage range:           | 88Vac – 264Vac universal mains input. (Withstanding 300Vac)        |          |          |
| Supply current (full load):              | <0.9A  | <1.0A    | <1.5A    |
| Quiescent Supply current (220Vac input): | <18mA  | <18mA    | <25mA    |
| Mains supply frequency range:            | 47Hz to 440Hz  |          |          |
| Efficiency (typical):                    | 85%  |          |          |
| DC supply input voltage range:           | 140Vdc to 300Vdc   |          |          |
| Operating temperature range:             | -25°C to +60°C   |          |          |
| Operating humidity range:                | 10%RH to 95%RH non-condensing                                      |          |          |
| Operating altitude:                      | 3000mt   |          |          |
| DC output voltage:                       | 13.8VDC  | 13.8VDC  | 27.6VDC  |
| DC output current (max):                 | 5.0Adc   | 10.0Adc  | 5.0Adc   |
| Output voltage ripple:                   | <100mV / noise <200mV pk-pk  |          |          |
| Charging Battery types:                  | VRLA Lead-Acid, AGM, Jell type                                     |          |          |
| AC/DC isolation:                         | Galvanically isolated to 4KVdc                                     |          |          |
| Model options:                           | Standard   | Standard | Standard |
|  | Foldback   | Boost    | Boost    |
| Alarm output:                            | SS transistor output, active LOW<br>Max. sink current: 300mA@24Vdc |          |          |
| Circuit protection:                      | Over voltage, short circuit, Reverse polarity, over-temperature,   |          |          |
| EMC Compliance:                          | EN61000-6-2/4<br>EN61000-4-4/5/6/11<br>UL94 V2 flammability        |          |          |
| Mounting type:                           | Panel mounting and rail mounting                                   |          |          |
| Enclosure protection class:              | IP20   |          |          |
| Overall dimensions:                      | 100x90x72mm  |          |          |
| Weight:                                  | 240gr  | 270gr    | 340gr    |

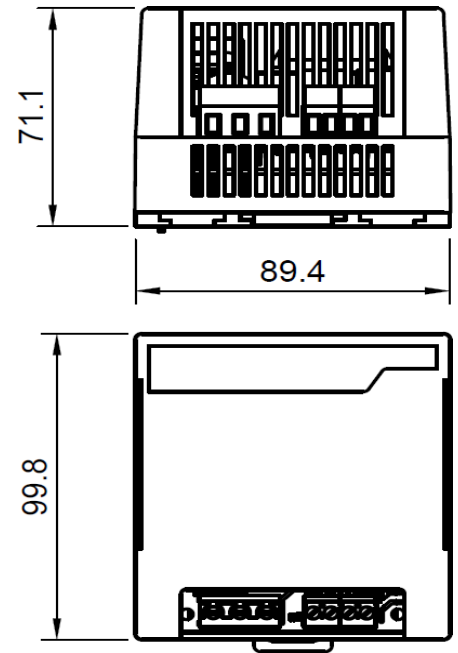
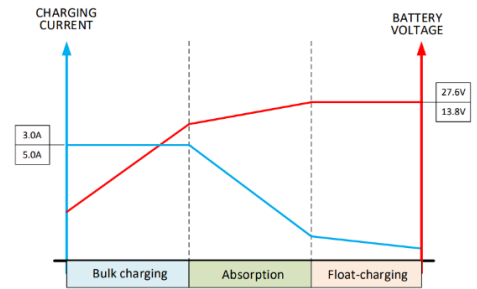

Figure1: Dimensions are shown in mm



Connection diagram:

Parallel configuration:

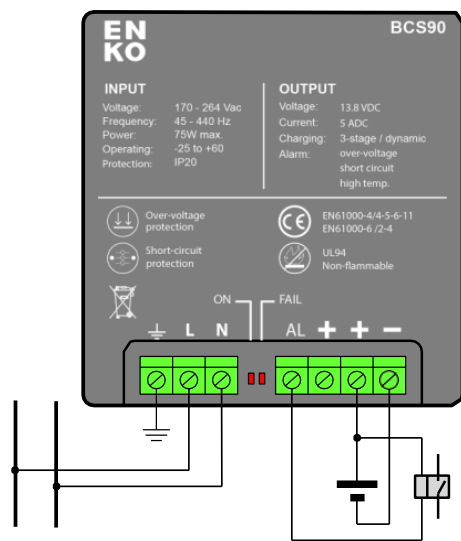

Figure2: External alarm relay with single battery.

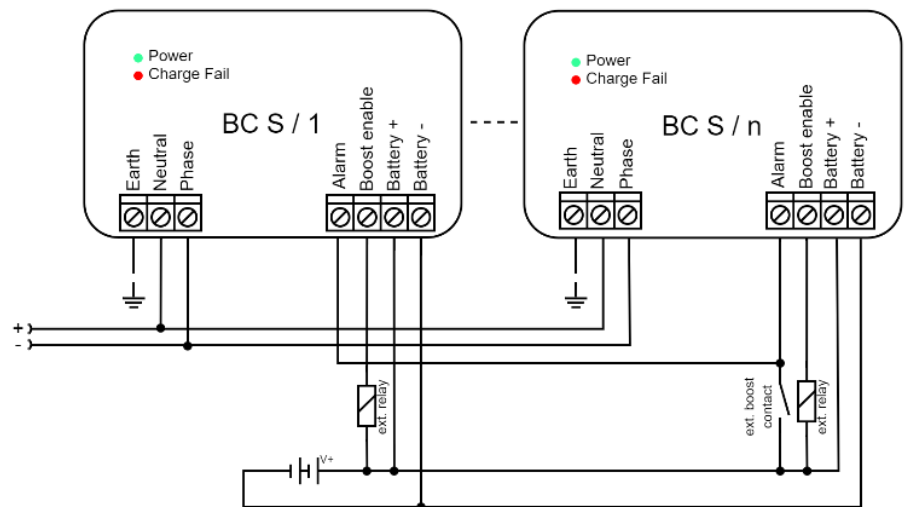

Figure3: Parallel Configuration diagram

EN  
KO

# EBC-Series

1205-1210-2405 SMPS Technology Battery Charge

## Product Description:

The EBC series chargers are designed with a high-efficiency and reliable "SMPS" design concept, suitable for all types of lead-acid and gel batteries. These chargers are ideal for applications requiring optimal performance of batteries used for starting (cranking) all kinds of engines. They feature "3-Stage Dynamic Charging" which maximizes battery capacity recovery.

Based on SMPS topology, the charging unit maintains high efficiency throughout the entire charging range. The charging DC current has minimal fluctuation, which extends the "Battery Life" and performance. EBC series chargers are designed to operate at full capacity across a very wide range of AC input supply voltages. Therefore, they operate reliably in applications where the power supply fluctuates significantly, restoring battery capacity in the shortest possible time.

EBC series chargers are equipped with all necessary protection functions to ensure high reliability under all conditions. Multiple chargers can be connected in parallel to increase capacity or for redundancy.

These chargers can deliver full rated current even in the event of a short circuit, so they can charge a battery even if it is completely depleted.

## Main Features

- ✓ 3-stage Dynamic Charging features
  - Initial stage
    - Equalizing stage
    - Float charge
- ✓ 150Vac - 275Vac Wide input voltage range
- ✓ High Efficiency >82%
- ✓ Wide operating temperature - 25°C to +60°C
- ✓ Low Load Regulation <100mV
- ✓ Line Regulation
- ✓ Low Output Voltage "Ripple"
- ✓ Reverse protection
- ✓ External BOOST control function
- ✓ Solid state Alarm output
- ✓ Alarm and operational status LED indicator
- ✓ Between AC input and DC output 4KV galvanic isolation
- ✓ CE conformity tests:
  - EN61000-6-2/4
  - EN61000-4-4/5/6/11

[info@enkoelektronik.com](mailto:info@enkoelektronik.com)

| Technical Specifications                 | Description   |                     |                    |
|--|---|---------------------|--------------------|
| EBC-Series                               | EBC-1205  | EBC-1210            | EBC-2405           |
| Supply current (full load):              | <0.9A   | <1.0A               | <1.5A              |
| Quiescent Supply current (220Vac input): | <18mA   | <18mA               | <25mA              |
| DC output voltage:                       | 13.8VDC   | 13.8VDC             | 27.6VDC            |
| DC output current (max):                 | 5.0A <sub>dc</sub>  | 10.0A <sub>dc</sub> | 5.0A <sub>dc</sub> |
| AC Supply input voltage range:           | 150Vac – 275Vac universal mains input. (Withstanding 300Vac)                      |                     |                    |
| Mains supply frequency range:            | 47Hz to 440Hz   |                     |                    |
| Efficiency (typical):                    | 82%   |                     |                    |
| DC supply input voltage range:           | 140V <sub>dc</sub> to 300V <sub>dc</sub>  |                     |                    |
| Operating temperature range:             | -25°C to +60°C  |                     |                    |
| Operating humidity range:                | 10%RH to 95%RH non-condensing   |                     |                    |
| Operating altitude:                      | 3000mt  |                     |                    |
| Output voltage ripple:                   | <100mV / noise <200mV pk-pk   |                     |                    |
| Charging Battery types:                  | VRLA Lead-Acid, AGM, Jell type  |                     |                    |
| AC/DC isolation:                         | Galvanically isolated to 4KV <sub>dc</sub>  |                     |                    |
| Model options:                           | Standard Foldback   | Standard            | Standard           |
|  | --  | Boost               | Boost              |
| Alarm output:                            | SS transistor output, active<br>LOW Max. sink current:<br>300mA@24V <sub>dc</sub> |                     |                    |
| Circuit protection:                      | Over voltage, short circuit, Reverse polarity, over-temperature,                  |                     |                    |
| EMC Compliance:                          | EN61000-6-2/4<br>EN61000-4-4/5/6/11<br>UL94 V2 flammability                       |                     |                    |
| Mounting type:                           | Panel mounting and rail mounting  |                     |                    |
| Enclosure protection class:              | IP20  |                     |                    |
| Overall dimensions:                      | 100x90x72mm   |                     |                    |
| Weight:                                  | 240gr   | 270gr               | 340gr              |

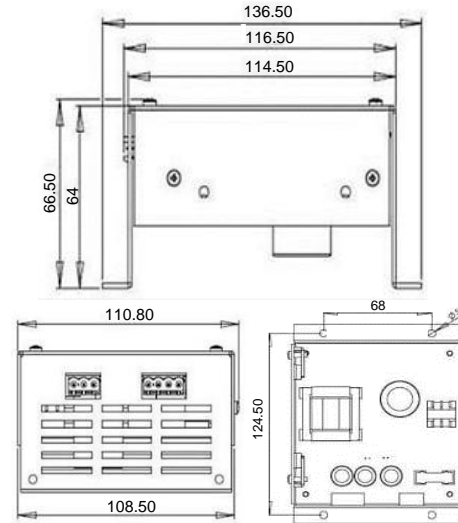

Typical Cell charging characteristics

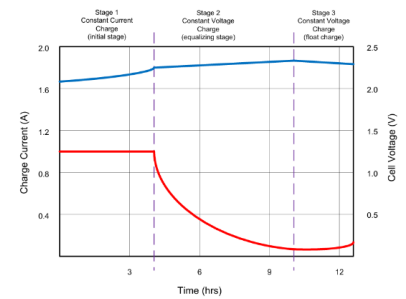

Connection diagram:

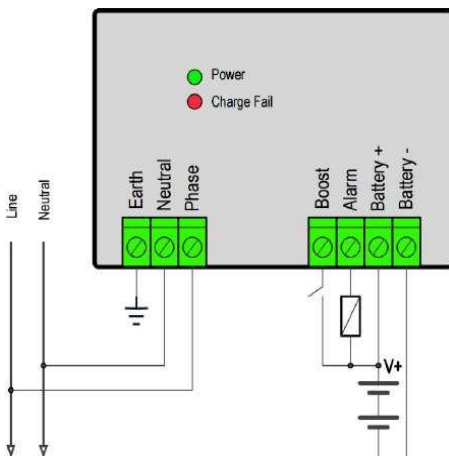

Figure2: External alarm relay with single

Parallel configuration:

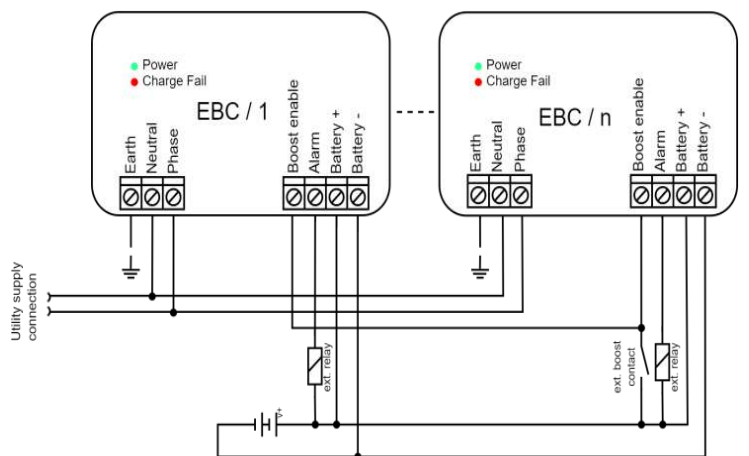

Figure3: Parallel Configuration Diagram

EN  
KO

# EBC-2410

SMPS Technology Battery Charge

## Product Description:

Our EBC-2410 battery chargers embody a cutting-edge SMPS (Switched-Mode Power Supply) design concept, providing high efficiency and reliability suited for all types of lead-acid and gel-type batteries. These chargers are perfect for applications that require maintaining batteries in peak condition to consistently start engines.

Featuring a "3-Stage Dynamic Charging" system, the EBC-2410 efficiently restores battery capacity to its maximum level. This SMPS- based charging unit ensures high efficiency across the entire charging range. The charging process delivers a DC current with minimal ripple, extending both the lifespan and performance of your batteries.

Designed to operate at full capacity within a broad range of AC input voltages, the EBC-2410 chargers reliably function even where power supply fluctuations are significant. They quickly restore battery capacity, ensuring your operations are up and running in no time.

To guarantee high reliability under all conditions, EBC-2410 chargers are equipped with all necessary protective features. For increased capacity or redundancy, multiple chargers can be connected in parallel.

These chargers can deliver full rated current even in the event of a short circuit, so they can charge a battery even if it is completely depleted.

### Main Features

- ✓ 3-stage Dynamic Charging features
  - Initial stage
  - Equalizing stage
  - Float charge
- ✓ 150Vac - 275Vac Wide input voltage range
- ✓ 25Vdc - 30Vdc adjustable output range
- ✓ High Efficiency >85%
- ✓ Wide Operating Temperature 25°C to +60°C
- ✓ Low Load Regulation <100mV
- ✓ Line Regulation
- ✓ Low Output Voltage "Ripple"
- ✓ Reverse protection
- ✓ External BOOST control function
- ✓ Solid state alarm output
- ✓ Alarm and operational status LED indicator
- ✓ Between AC input and DC output 4KV galvanic isolation
- ✓ CE conformity tests:
  - EN61000-6-2/4
  - EN61000-4-4/5/11

[info@enkoelektronik.com](mailto:info@enkoelektronik.com)

| Technical Specifications       | Description  |
|--------------------------------|--|
| DC output voltage:             | 27.6VDC (25.5 – 30Vdc) adjustable output voltage                                 |
| DC output current (max.):      | 10.0A <sub>dc</sub>  |
| Supply current (@full load):   | <2.50A   |
| Weight:                        | 700 g (Approx.)  |
| Overall dimensions:            | 122. x 200 x 75.4 mm   |
| AC Supply input voltage range: | 150Vac- 275Vac universal mains input (withstand 300Vac)                          |
| Mains supply frequency range:  | 45Hz to 450Hz  |
| Productivity (Typical):        | 85%  |
| DC supply input voltage range: | 250V <sub>dc</sub> - 400V <sub>dc</sub>  |
| Operating temperature range:   | -25°C- +60°C   |
| Storage temperature:           | -30°C- +80°C temperature range   |
| Operating humidity range:      | 10% rh- 95% rh non-condensing  |
| Operating height:              | 3000mt   |
| Load Regulation:               | Zero to Full load <0.2V  |
| Line Regulation:               | 0.1V Max. Voltage range over full input  |
| Output Voltage ripple:         | <1.0% of rated output voltage above 10Hz to 100KHz                               |
| Boost Charge Voltage:          | Rated output voltage +0.8V <sub>dc</sub> upon activation (optional)              |
| Battery Options:               | VRLA Lead-Acid, AGM, Jell type   |
| AC/DC isolation:               | Galvanically isolated up to 4KV <sub>dc</sub>                                    |
| Alarm output:                  | Solid state, active Low Max. sink current: 200mA@24V <sub>dc</sub>               |
| Protections:                   | Short circuit, Reverse polarity (with built-in fuse)                             |
| EMC Compliance:                | EN61000-6-2- EN61000-6-4 - EN61000-4-4 - EN61000- 4-5 EN61000-4-6 - EN61000-4-11 |
| Protection class:              | IP00   |

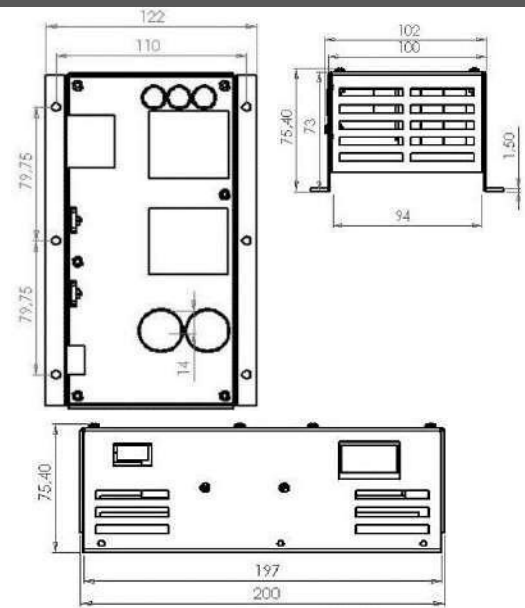
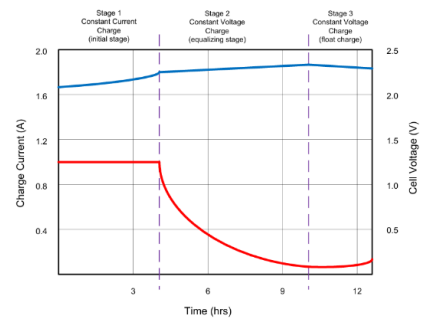

Figure1: Dimensions are shown in mm

Typical Cell charging characteristics



Connection Diagram

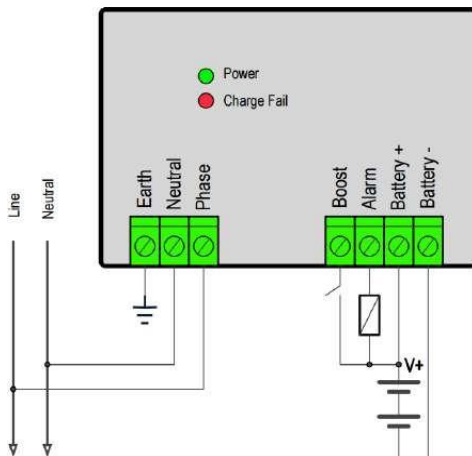

Figure2: External alarm relay with single

Parallel Configuration

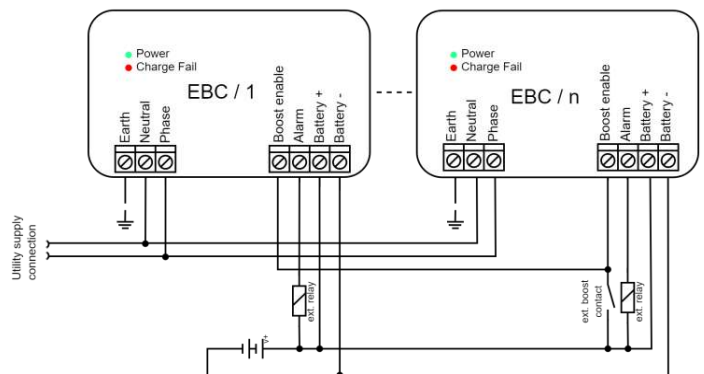

Figure3: Parallel Configuration Diagram

# EN KO

BATTERY  
CHARGE



# EBCH-2420

SMPS Technology Battery Charge

## Product Description:

The EBCH-2420 chargers are based on the "SMPS" design concept, suitable for all types of lead-acid and gel batteries, offering high efficiency and reliability. These chargers are ideal for applications where it is crucial to maintain the battery used to start all types of engines (ignition) at optimal performance. They feature "3-Stage Dynamic Charging" which maximizes battery capacity recovery.

The charging unit, based on SMPS topology, maintains high efficiency throughout the entire charging range. The charging DC current has minimal fluctuation, which extends the "Battery Life" and performance. EBCH-2420 chargers are designed to operate at full capacity across a very wide AC input voltage range. Therefore, they operate reliably in applications where the power supply fluctuates significantly, restoring battery capacity in the shortest possible time.

EBCH-2420 chargers are equipped with all necessary protective functions to ensure high reliability under all conditions. Multiple chargers can be connected in parallel to increase capacity or for redundancy.

These chargers can deliver full nominal current even in the event of a short circuit, thus capable of charging a battery even if it is completely depleted.

## Main Features

- ✓ 3-stage Dynamic Charging features
  - Initial stage
  - Equalizing stage
  - Float charge
- ✓ 150Vac - 275Vac Wide input voltage range
- ✓ High Efficiency >82%
- ✓ Wide operating temperature - 25°C to +60°C
- ✓ Low Load Regulation <100mV
- ✓ Line Regulation
- ✓ Low Output Voltage "Ripple"
- ✓ Reverse protection
- ✓ External BOOST control function
- ✓ Solid state Alarm output
- ✓ Alarm and operational status LED indicator
- ✓ Between AC input and DC output 4KV galvanic isolation
- ✓ CE conformity tests:
  - EN61000-6-2/4
  - EN61000-4-4/5/6/11

[info@enkoelektronik.com](mailto:info@enkoelektronik.com)

| Technical Specifications       | Description  |
|--------------------------------|--|
| DC output voltage:             | 27.6VDC (25.5 – 30Vdc) ad justable output voltage  |
| DC output current (max.):      | 20.0A dc   |
| Supply current (@full load):   | <5.5A  |
| Weight:                        | 1400g (Approx.)  |
| Overall dimensions:            | 236x 126 x 82 mm   |
| AC Supply input voltage range: | 150Vac- 275Vac universal mains input (withstand 300Vac)                                    |
| Mains supply frequency range:  | 45Hz to 450Hz  |
| Productivity (Typical):        | 85%  |
| DC supply input voltage range: | 250Vdc- 400Vdc   |
| Operating temperature range:   | -25°C- +60°C   |
| Storage temperature:           | -30°C- +80°C temperature range   |
| Operating humidity range:      | 10% rh- 95% rh non-condensing  |
| Operating height:              | 3000mt   |
| Load Regulation:               | Zero to Full load <0.4V  |
| Line Regulation:               | 0.1V Max. Voltage range over full input  |
| Output Voltage ripple:         | Rated output from 10Hz to over 100KHz voltage < 1.0%Khz                                    |
| Boost Charge Voltage:          | Rated output voltage +0.8Vdc upon activation   |
| Battery Options:               | VRLA Lead-Acid, AGM, Jell type   |
| AC/DC isolation:               | Galvanically isolated up to 4KVdc  |
| Alarm output:                  | Fault Output (Relay) 1A@24Vdc  |
| Protections:                   | Short circuit, reverse polarity, Over voltage protection, heat protection (Power dreading) |
| EMC Compliance:                | EN61000-6-2- EN61000-6-4-EN61000-4-4-EN61000-4-5 EN61000-4-6 - EN61000-4-11                |
| Mounting:                      | Rail Mounting  |
| Protection class:              | IP20   |

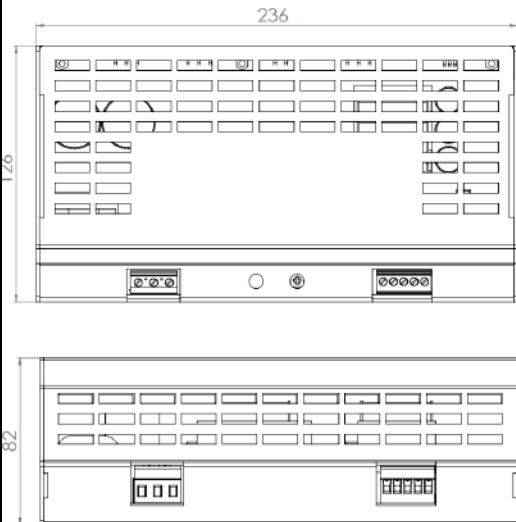
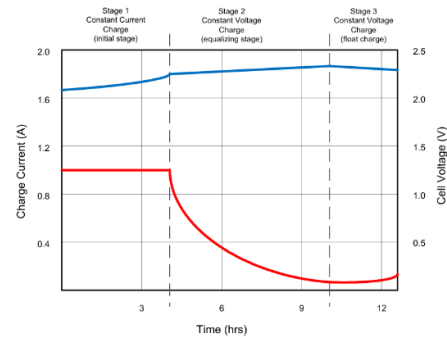

Figure1: Dimensions are shown in mm

Typical Cell charging characteristics



Connection diagram:

Parallel configuration:

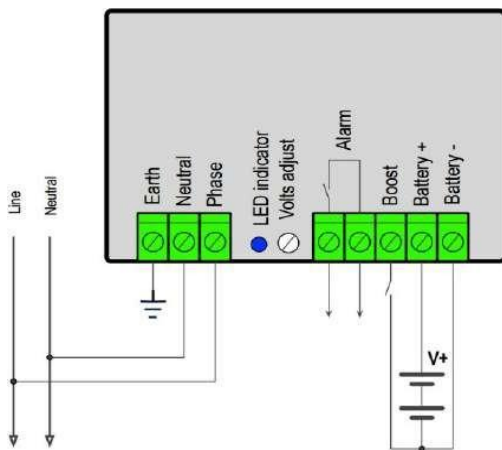

Figure2: External alarm relay with single

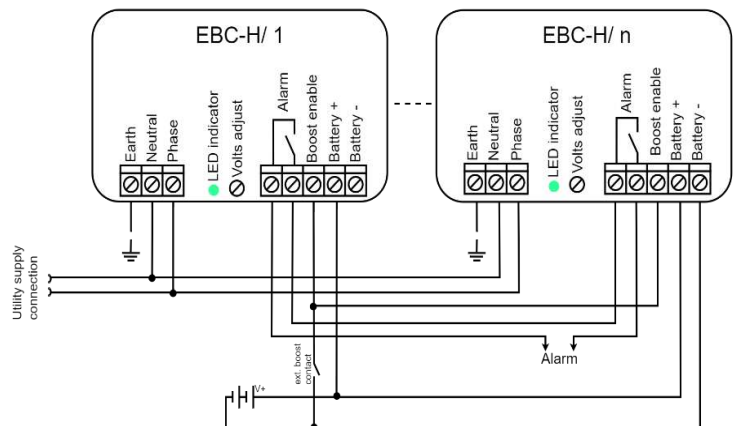
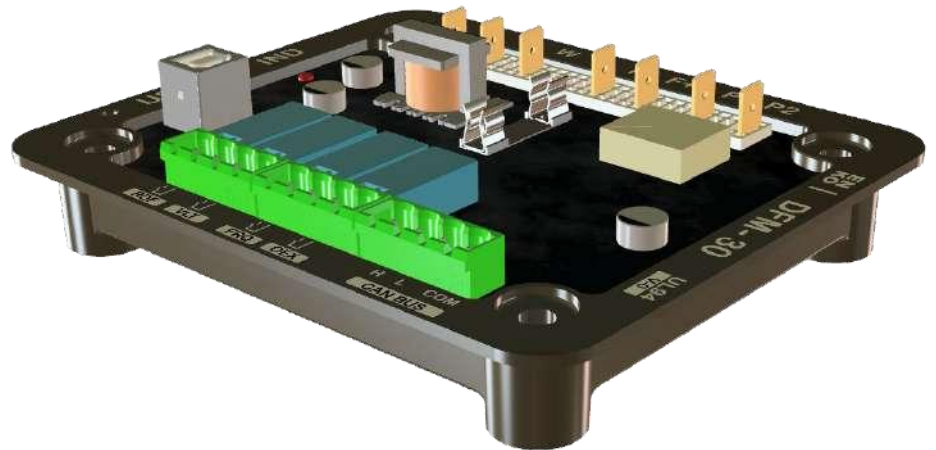

Figure3: Parallel Configuration Diagram

COMING  
SOONEN  
KO

# DFM-30

## Diode Failure Monitor Unit For Synchronous Alternators

### Product Description:

DFM-30 is a “State-of-the-Art” design to be implemented into any generator system to detect and monitor critical failure modes for Synchronous Alternators. This protection unit is essential for high-reliability generator applications, where critical load protection is required at a very high level of reliability and at the same time, reduce servicing time in the field.

DFM-30 protection module measures 3-phase stator voltage and at the same time monitors the FIELD drive of the alternator. Embedded transformation algorithm monitors the dynamic ROTOR diode rectifier characteristics and if one or more diodes fail to operate, an alarm relay sends a signal to the control system to initiate the necessary protection or warning procedure in the generator system. Embedded algorithm also monitors the rotor winding behaviour and initiates an alarm contact for the generator control panel.

DFM-30 also monitors all stator phases, and the user can set alarm limits for over and under voltage and frequency values to initiate protection of the alternator. Options are available for temperature and stator current monitoring and to initiate consecutive protection and/or warning to the generator control system. Stator unbalance and harmonics content can also be monitored by DFM-30 for extensive protection in demanding applications.

The unit has a built-in FUSE holder to protect the FIELD winding and if DFM-30 is used on the alternator, there will be no need for an additional fuse holder for the excitor protection.

DFM-30 unit has built-in CAN bus interface such that, all the measured parameters of the alternator system can be reached by the generator control panel. On board USB interface communication port allows the unit to be configured when the generator is in OFF position. A PC-Tool software is available to configure the unit.

DFM-30 can be interfaced to any existing generator, regardless of the power rating and/or its manufacturer, giving extensive protection and monitoring capability in demanding applications.

### Main Features

- ✓ Provides complete protection and monitoring of critical alternator parameters during operation,
- ✓ Monitors ROTOR diode block and generates alarm if there is a failure in the rotor rectifier block,
- ✓ Monitors rotor windings,
- ✓ Monitors 3-phase TRUE RMS stator phase voltages, frequency, and harmonic content,
- ✓ Option for measuring stator load current and winding temperature,
- ✓ Option for measured parameters data logging, alarms, and event logging,
- ✓ Embedded glass fuse holder to protect the FIELD winding,
- ✓ True OEX function can be programmed for excess load on the field winding during operation,
- ✓ Built-in CAN bus for interfacing with generator control panel during operation,
- ✓ USB communication port for system parameter configuration
- ✓ Encapsulated construction for extreme environmental operating conditions,
- ✓ Construction is resistant to high vibration mounting,
- ✓ CE compliant for EMC emissions,
- ✓ UL compliant safety standards

[info@enkoelektronik.com](mailto:info@enkoelektronik.com)

| Technical Specifications                 | Value  | Description                                  |
|--|--|--|
| Sensing voltage range:                   | 120Vac to 576Vac   | 3-phase or 2-phase connection                |
| Sensing voltage resolution:              | TRUE RMS calculation, <0.1% error  |  |
| Power supply connection:                 | 2-phase / Phase-Neutral  | 300Vac maximum limit                         |
| Power dissipation:                       | 4W maximum   | All relays activated                         |
| Operating frequency range:               | 45Hz to 440Hz  | With no measurement degradation              |
| Operating temperature range:             | -40°C to +70°C   | non-condensing                               |
| Operating humidity range:                | 20%RH to 95%RH   |  |
| EXCITATION current monitoring:           | 0.00Adc – 15.0Adc  | Programmable limits / resolution             |
| FIELD OEX protection:                    | 100% to 200%   | Programmable according to alternator data    |
| OEX activation delay time:               | 0 sec to 3600 seconds  | Programmable time delay                      |
| ROTOR Diode Failure Detection:           | YES  | One or multiple diode failure detection      |
| ROTOR Winding failure Detection:         | YES  | Short circuit detection                      |
| Over / Under voltage detection:          | YES  | Programmable trigger limits and time delay   |
| Over / Under frequency detection:        | YES  |  |
| Stator winding temperature detection:    | YES  | Optional features                            |
| Stator load monitoring:                  | YES  |  |
| Data logging, alarms, and event logging: | YES  |  |
| EXCITATION protection fuse:              | YES (built-in)   | Standard glass fuse, up to 30A rating        |
| Alarm outputs:                           | 4 x N/O contacts   | Energized during operation (closed contacts) |
| Communication port:                      | USB Type-2   | System parameter configuration               |
|  | CAN BUS  | System network connection                    |
| EMC Compliance:                          | EN61000-6-2/4 EN6068-1-2-14-30<br>UL94 V2 flammability safety compliance |  |
| Enclosure protection class:              | Electronic components protected with PU encapsulation                    |  |
| Overall dimensions:                      | 115x95x32mm  |  |
| Weight:                                  | 190gr  |  |

## Connection Diagram:

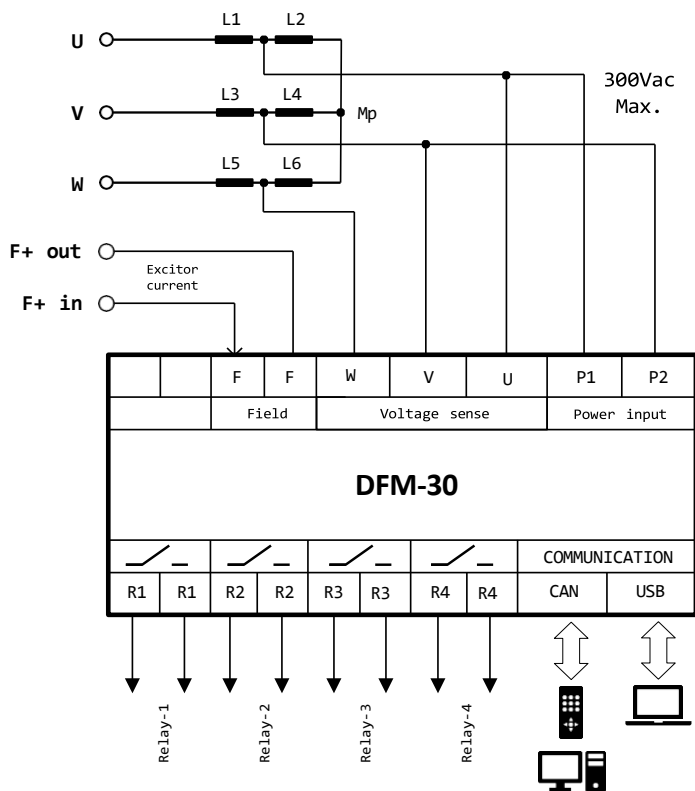

## Mechanical Dimensions:

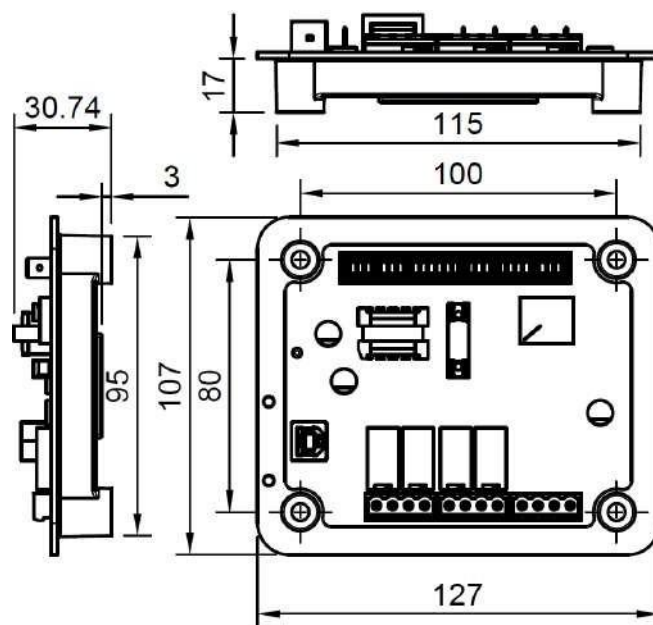

### Compliance:

DFM-30 is tested and compliant to CE regulations for emitted and conducted RFI interference, according to EN61000-6-4. Immunity is tested against EN61000-6-2. Vibration: EN60068-6-2 Dielectric strength: IEC255, Flammability: UL94, Safety: UL508

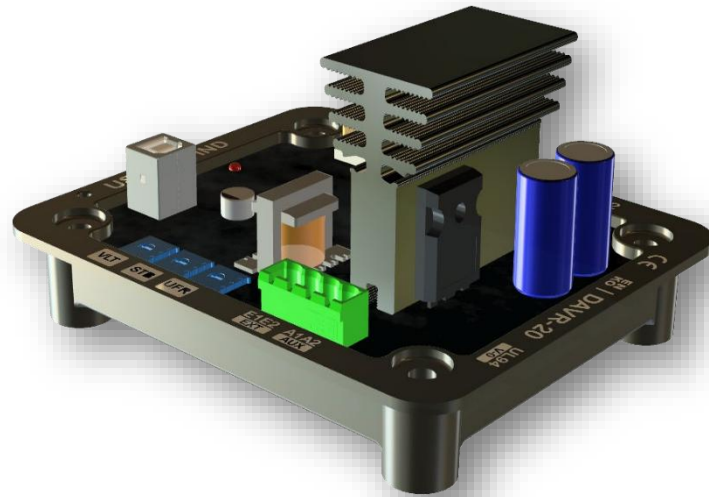
EN  
KO

# DAVR20

## Digital Voltage Regulators for Synchronous Alternators

### Product Description:

DAVR20 is a “Digital Voltage Regulator”, designed for high-performance operation in cost sensitive applications. The unit has small footprint with robust plastic tray and encapsulation for operation in tight space and with little or no ventilation.

The AVR design is based on “true” digital architecture, where the stator voltages are measured with high precision and the excitation winding is driven with high frequency PWM signals. The “State-of-the-Art” firmware algorithm controls all PID functions in a very smooth fashion, allowing the AVR unit to control any size alternator with optimum performance under any load conditions. High-speed digital reading of the sense voltage allows computation at higher harmonics of the fundamental signal, which enables very tight voltage regulation with high harmonic loads, such as inverters or similar switching loads.

DAVR20 is furnished with complex dynamic features such as high BLOCK-LOAD handling capability (LAM function) and compliance to ISO8528-5 standard under dynamic load operating conditions. Fast response and transfer function control within the AVR unit allows optimum dip and rise performance sudden “load” and “unload” conditions. This feature can downsize the prime-mover power requirement for a given generator capacity, compared to analogue AVR units.

For stand-alone generator applications, DAVR20 offers best cost-performance ratio on the market and can be used with any size and brand alternators. External control signals can also be connected to the AVR unit through AUX inputs and allows remote control of the AVRs, connected to an external controller.

On board USB port can be used for configuring the AVR via dedicated PC Tool software package. All parameters of the AVR unit can be set and monitored via USB com port and dynamic performance of the alternator can be monitored using the “data logger” menu in the PC-Tool software package.

### Main Features

- ✓ TRUE Digital design concept,
- ✓ Performance compliance to ISO8528-5 standard,
- ✓ Continuous Excitation drive capability, in excess of 5A<sub>dc</sub>,
- ✓ Integrated LAM function control to improve BLOCK-LOAD handling capability of the generator,
- ✓ SHUNT and AUXILIARY power connection capability,
- ✓ TRUE RMS sense voltage measurement for precise voltage regulation in high-harmonic distorted load conditions,
- ✓ 2-phase sensing capability,
- ✓ AUXILIARY analogue inputs for external control of AVR functions,
- ✓ Excellent stability control through digital signal processing,
- ✓ USB communication port for system parameter configuration and monitoring,
- ✓ Encapsulated construction for extreme environmental operating conditions,
- ✓ Construction is resistant to high vibration mounting,
- ✓ CE compliant for EMC emissions,
- ✓ UL compliant safety standards

[info@enkoelektronik.com](mailto:info@enkoelektronik.com)

| Technical Specifications     | Value  | Description  |
|------------------------------|--|--|
| Sensing voltage range:       | 100Va 576Vac   | 2-phase connection   |
| Power connection to AVR:     | SHUNT / AUXILIARY  | 300Vac maximum limit   |
| Voltage regulation:          | <0.5%  | No-load to full load, PF>0.8 and $\Delta T < 40^{\circ}\text{C}$ |
| Voltage sensing type:        | TRUE RMS calculation, capable of operation with high harmonic loads                  |  |
| Operating frequency:         | 20 Hz to 80Hz  |  |
| Operating temperature range: | -35°C to +60°C   | 30%RH to 95%RH non-condensing                                    |
| Voltage adjustment:          | On-board trimmer   | $\pm 20\%$ of selected voltage range                             |
|                              | External pot trimming  | $\pm 10\%$ of set voltage value                                  |
|                              | AUX input signal   | $\pm 15\%$ of set voltage value                                  |
| Excitation current:          | 5A <sub>dc</sub> continuous  | Rated over full operating temperature range                      |
|                              | 7A <sub>dc</sub> 120 seconds   |  |
|                              | 10A <sub>dc</sub> for 10 seconds   |  |
| FIELD impedance range:       | 5Ω to 50Ω  | 15Ω nominal winding impedance                                    |
| FIELD drive:                 | Thyristor Control ?  | High resolution control  |
| AUX. signal input:           | Analogue voltage input, External pot input   |  |
| LAM function:                | BLOCK-LOAD acceptance limit setting with integrated comprehensive algorithm,         |  |
| EMC Compliance:              | EN61000-6-2/4 EN6068-1-2-14-30<br>In progress UL94 V2 flammability safety compliance |  |
| Protection functions:        | LOS  | Loss of sensing voltage protection                               |
|                              | OEX-IDMT field   | Over Excitation protection                                       |
|                              | GUV  | Generator under voltage  |
|                              | GOV  | Generator over voltage   |
| Communication port:          | USB Type-B   | System configuration and monitoring                              |
| Enclosure protection class:  | Electronic components protected with PU encapsulation                                |  |
| Overall dimensions:          | 100x95x57.5mm  |  |
| Weight:                      | 190gr  |  |

## Connection Diagram:

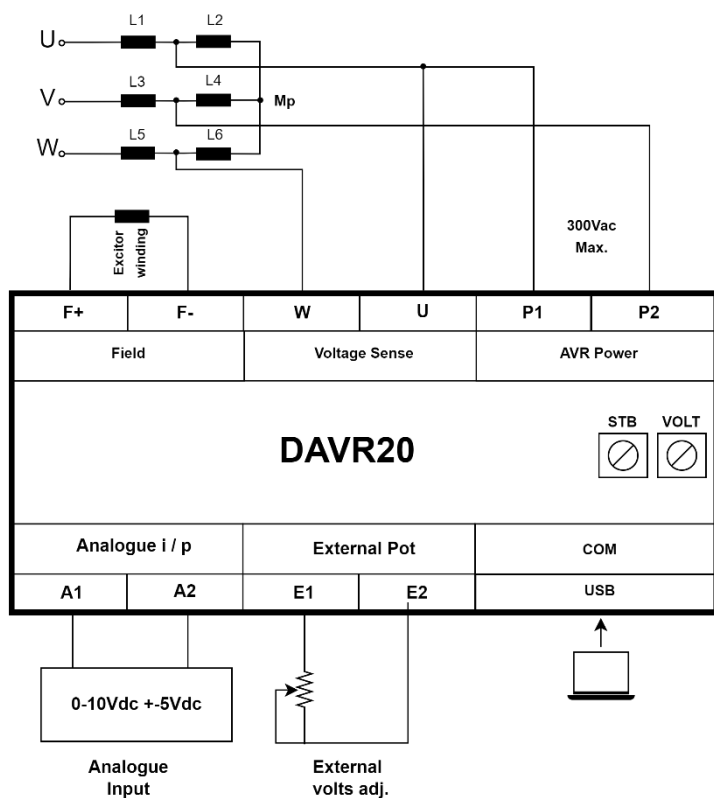

## Mechanical Dimensions:

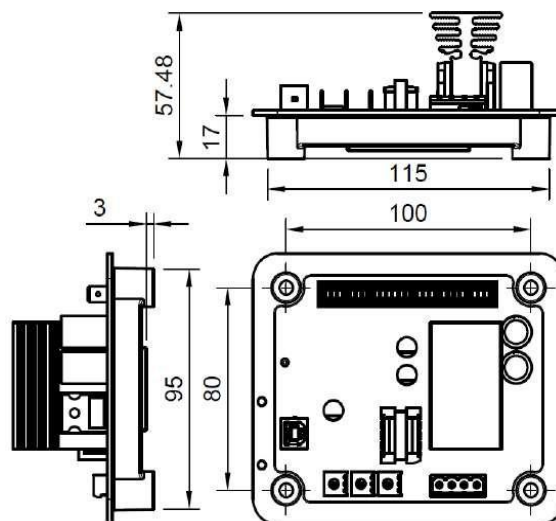

### Compliance:

DAVR20 is tested and compliant to CE regulations for emitted and conducted RFI interference, according to EN61000-6-4. Immunity is tested against EN61000-6-2. Vibration: EN60068-6-2 Dielectric strength: IEC255, Flammability: UL94, Safety: UL508

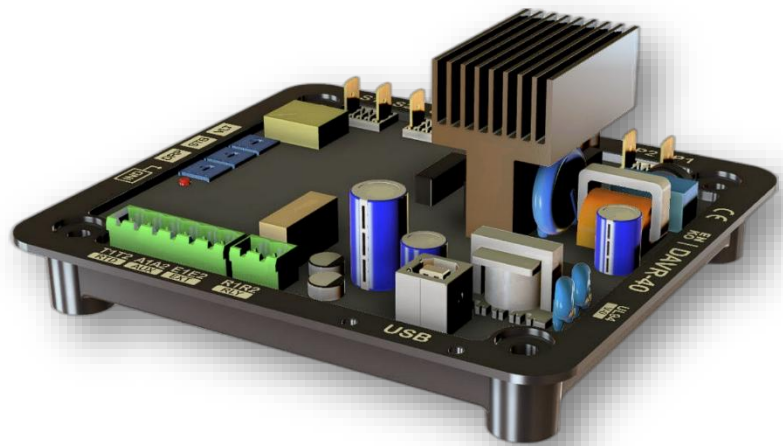
EN  
KO

# DAVR40

## Digital Voltage Regulators for Synchronous Alternators

### Product Description:

DAVR40 is a “microcontroller integrated voltage regulator unit”, designed for high performance, with generators operating into dynamically complex loads. This AVR model offers high-performance operation with relatively low cost, by utilising an SCR controlled power stage for excitation of the alternator. It can deliver continuous 5.0Adc excitation power into the FIELD winding and can handle 130% overload for a minimum duration of 120 seconds.

DAVR40 is digitally synthesised so that; sense voltage is measured with high sampling rates, which enables stable voltage regulation even with very high harmonic distorted loads. This is particularly critical with inverter type switching loads.

Power input to AVR can be connected in SHUNT mode or with AUXILIARY winding of the alternator with over 1.5KVA input power rating.

DAVR40 is designed with integrated “**Block Load Module**” (BLM®) function, which monitors the behavior of the generator by making fast FFT waveform analyses and relaxes the burden on the engine so that; engine capacity can be down-sized compared to competition on the market. This brings a big advantage when the generator is designed according to ISO8528 standard.

“Reactive Load Sharing” is also an integrated feature and has excellent performance. Generators running in parallel can be fine-tuned with on-board trimmer pot. Also, VOLTS and STAB values can be set with the on-board trimmers. All other functions can be trimmed according to customer’s specific requirements by using the on-board USB port with free supplied PC Tools SW package.

Alarm conditions can be linked to any limit of the AVR parameters, using PC Tools SW package. On-board integrated ALARM relay has SPST N/C contact, which can be controlled to trigger specific protection sequences directly from the AVR unit.

DAVR40 has also a built-in RTD temperature sensor input, which can be used to monitor critical temperatures on the alternator unit during operation. This feature can also be linked directly to the ALARM relay so that, if there are any excess temperature conditions, automatic load shedding sequences can be initiated via this function. This is a very useful feature, if the generator is operating under very harsh conditions.

AUX inputs on the AVR unit can be used to control the AVR voltage via external intelligent control devices and set the voltage using EXT trimming potentiometers. Both inputs can be configured via PC Tools SW package.

### Main Features

- ✓ Microprocessor based design for high-performance,
- ✓ Continuous Excitation drive capability, in excess of 5Adc, 130% overload capacity for 120 sec.,
- ✓ Integrated BLM® function control to improve BLOCK-LOAD handling capability of the generator,
- ✓ TRUE RMS sense voltage measurement for precise voltage regulation in high-harmonic distorted load conditions,
- ✓ SHUNT and AUX connection modes for power input to AVR,
- ✓ AUXILIARY analogue inputs for external control of AVR functions,
- ✓ EXT temperature sensing input for alternator winding safety.
- ✓ Excellent stability control through digital signal processing,
- ✓ “LINE” compensation or “QUADRATURE DROOP” compensation by parameter configuration setting,
- ✓ ALARM relay output for external safety sequence control of the generator,
- ✓ USB communication port for AVR parameter configuration,
- ✓ Secure fast-on terminals for power connections,
- ✓ Encapsulated construction for extreme environmental operating conditions,
- ✓ Construction is resistant to high vibration mounting,
- ✓ CE compliant for EMC emissions,
- ✓ UL compliant safety standards,

[info@enkoelektronik.com](mailto:info@enkoelektronik.com)

| Technical Specifications      | Value  | Description  |
|-------------------------------|--|--|
| Sensing voltage range:        | 100Vac to 576Vac   | 3-phase or 2-phase sense input connection          |
| Power connection to AVR:      | Shunt / Auxiliary  | 300Vac maximum limit                               |
| Voltage regulation:           | <0.5%  | No-load to full load, PF>0.8 and ΔT<40°C           |
| Voltage sensing type:         | TRUE RMS calculation, capable of operation with high harmonic loads          |  |
| Operating frequency:          | 20Hz to 80Hz   |  |
| Operating temperature range:  | -35°C to +60°C   | 30%RH to 95%RH non-condensing                      |
| Voltage adjustment:           | On-board trimmer   | ±20% of selected voltage range                     |
|                               | External pot trimming  | ±10% of set voltage value                          |
|                               | AUX input signal   | ±15% of set voltage value                          |
| Current sensing:              | X/1 or X/5 Class-1 CT (on-board)   | Single-phase sensing, fitted on alternator phase-V |
| CT burden:                    | 1VA (3VA maximum)  |  |
| Current sensing compensation: | DROOP compensation   | Reactive load compensation                         |
|                               | LINE compensation  | Load dependent line DROP compensation              |
| Excitation current:           | 5.0A dc continuous   | Rated at maximum operating temperature conditions. |
|                               | 6,25A dc 120 seconds   |  |
|                               | 7.0A dc for 10 seconds   |  |
| FIELD impedance range:        | 5Ω to 50Ω  | 15Ω nominal winding impedance                      |
| FIELD drive:                  | Thyristor Control  | High Resolution Control                            |
| AUX. signal input:            | Analogue voltage input, External pot input                                   |  |
|                               | Temperature input for RTD type sensor  |  |
| BLM <sup>®</sup> function:    | BLOCK-LOAD acceptance limit setting with integrated comprehensive algorithm, |  |
| Protection functions:         | LOS  | Loss of sensing voltage protection                 |
|                               | OEX-IDMT Field   | Over Excitation protection                         |
|                               | GUV- GOV   | Generator Under / Over Voltage                     |
|                               | SVU  | Generator Voltage Unbalance                        |
|                               | GCL  | Generator Current Limit                            |
|                               | WTA-WTL  | Winding Temperature Limit / Alarm                  |
| ALARM Output:                 | 2A ac SPST N/C contact   | Configurable via PC Tools SW package               |
| Communication Port:           | USB COMM port  | For AVR parameter configuration                    |
| EMC Compliance:               | EN61000-6-2, EN61000-6-4   |  |
|                               | EN6068-1-2-14-30   |  |
|                               | In Progress UL94 V2 flammability safety compliance                           |  |
| Enclosure protection class:   | Electronic components protected with PU encapsulation                        |  |
| Overall dimensions:           | 142x127x58 mm  |  |
| Weight:                       | 220gr  |  |

## Connection Diagram:

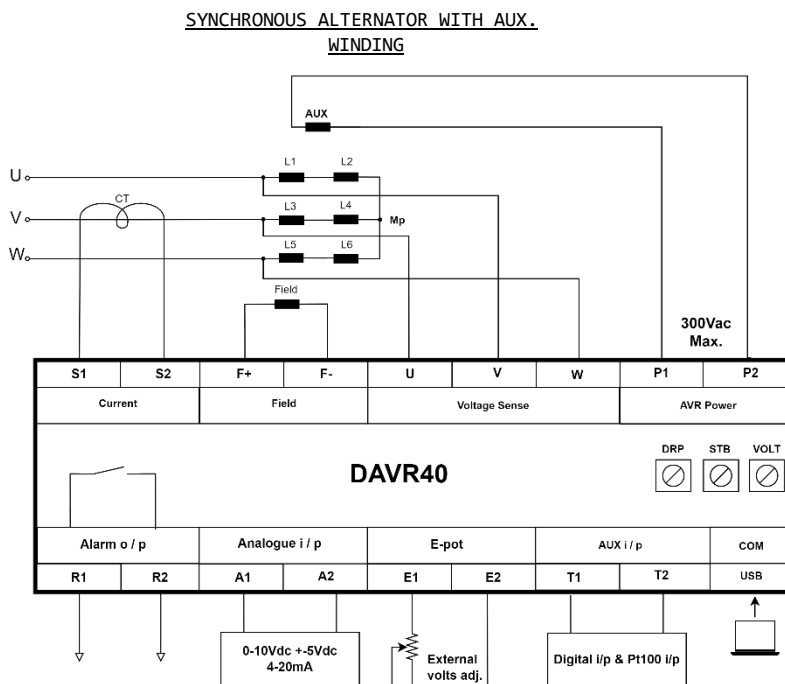

## Mechanical Dimensions:

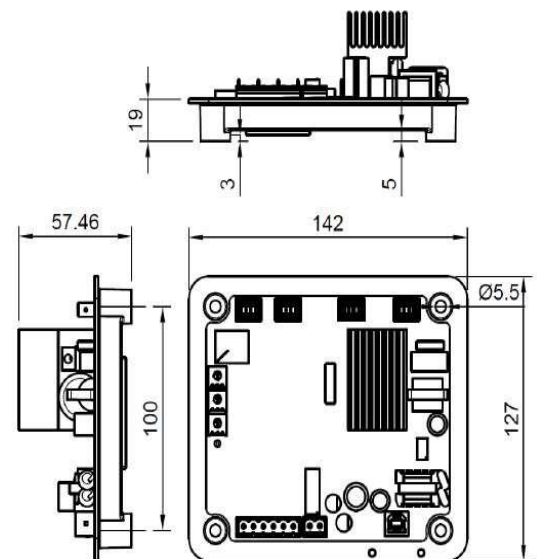

**Compliance:**

DAVR40 is tested and compliant to CE regulations for emitted and conducted RFI interference, according to EN61000-6-4. Immunity is tested against EN61000-6-2. Vibration: EN60068-5-2 Dielectric strength: IEC255, Flammability: UL94, Safety: UL508

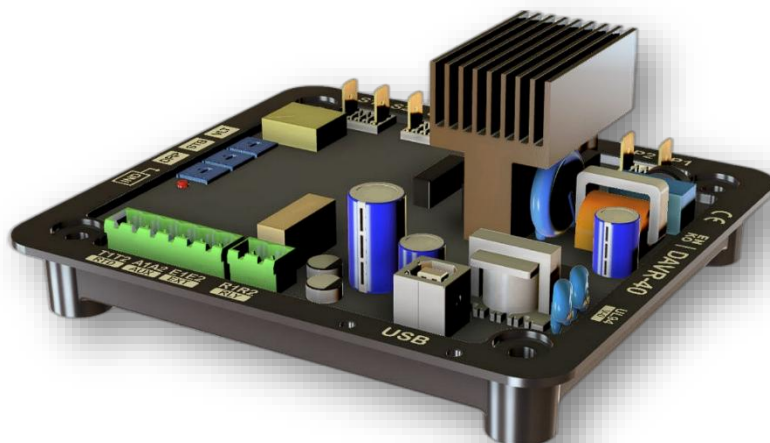
EN  
KO

# DAVR45

## Digital Voltage Regulators for Synchronous Alternators

### Product Description:

DAVR45 is a “microcontroller integrated voltage regulator unit”, designed for high performance, with generators operating into dynamically complex loads. This AVR model offers high-performance operation with relatively low cost, by utilizing an SCR controlled power stage for excitation of the alternator. It can deliver continuous 5.0A<sub>dc</sub> excitation power into the FIELD winding and can handle 130% overload for a minimum duration of 120 seconds.

DAVR45 is digitally synthesized so that sense voltage is measured with high sampling rates, which enables stable voltage regulation even with very high harmonic distorted loads. This is particularly critical with inverter type switching loads.

Power input to AVR can be connected in SHUNT mode or with AUXILIARY winding of the alternator with over 1.5KVA input power rating.

DAVR45 is designed with integrated “**Block Load Module**” (BLM<sup>®</sup>) function, which monitors the behavior of the generator by making fast FFT waveform analyses and relaxes the burden on the engine so that; engine capacity can be down-sized compared to competition on the market. This brings a big advantage when the generator is designed according to ISO8528 standard.

“Reactive Load Sharing” is also an integrated feature and has excellent performance. Generators running in parallel can be fine-tuned with on-board trimmer pot. Also, VOLTS and STAB values can be set with the on-board trimmers. All other functions can be trimmed according to the customer’s specific requirements by using the on-board USB port with free supplied PC Tools SW package.

Alarm conditions can be linked to any limit of the AVR parameters, using PC Tools SW package. On-board integrated ALARM relay has SPST N/C contact, which can be controlled to trigger specific protection sequences directly from the AVR unit.

DAVR45 has also a built-in RTD temperature sensor input, which can be used to monitor critical temperatures on the alternator unit during operation. This feature can also be linked directly to the ALARM relay so that, if there are any excess temperature conditions, automatic load shedding sequences can be initiated via this function. This is a very useful feature, if the generator is operating under very harsh conditions.

AUX inputs on the AVR unit can be used to control the AVR voltage via external intelligent control devices and set the voltage using EXT trimming potentiometers. Both inputs can be configured via PC Tools SW package.

### Main Features

- ✓ Microprocessor based design for high-performance,
- ✓ Continuous Excitation drive capability, in excess of 5A<sub>dc</sub>, 130% overload capacity for 120 sec.,
- ✓ Integrated BLM<sup>®</sup> function control to improve BLOCK-LOAD handling capability of the generator,
- ✓ TRUE RMS sense voltage measurement for precise voltage regulation in high-harmonic distorted load conditions,
- ✓ SHUNT and AUX connection modes for power input to AVR,
- ✓ AUXILIARY analogue inputs for external control of AVR functions,
- ✓ EXT temperature sensing input for alternator winding safety.
- ✓ Excellent stability control through digital signal processing,
- ✓ “LINE” compensation or “DROOP” compensation by parameter configuration setting,
- ✓ ALARM relay output for external safety sequence control of the generator,
- ✓ USB communication port for AVR parameter configuration,
- ✓ Secure fast-on terminals for power connections,
- ✓ Encapsulated construction for extreme environmental operating conditions,
- ✓ Construction is resistant to high vibration mounting,
- ✓ CE compliant for EMC emissions,
- ✓ UL compliant safety standards

| Technical Specifications      | Value  | Description  |
|-------------------------------|--|--|
| Sensing voltage range:        | 100Vac to 576Vac   | 3-phase or 2-phase sense input connection          |
| Power connection to AVR:      | Shunt / Auxiliary  | 300Vac maximum limit                               |
| Voltage regulation:           | <0.25%   | No-load to full load, PF>0.8 and ΔT<40°C           |
| Voltage sensing type:         | TRUE RMS calculation, capable of operation with high harmonic loads          |  |
| Operating frequency:          | 20Hz to 80Hz   |  |
| Operating temperature range:  | -35°C to +60°C   |  |
| Voltage adjustment:           | On-board trimmer   | ±20% of selected voltage range                     |
|                               | External pot trimming  | ±10% of set voltage value                          |
|                               | AUX input signal   | ±15% of set voltage value                          |
| Current sensing:              | X/5 Class-1 CT (on-board)  | Single-phase sensing, fitted on alternator phase-V |
| CT burden:                    | 1VA (3VA maximum)  |  |
| Current sensing compensation: | DROOP compensation   | Reactive load compensation                         |
|                               | LINE compensation  | Load dependent line DROP compensation              |
| Excitation current:           | 5.0Adc continuous  | Rated at maximum operating temperature conditions. |
|                               | 6,25Adc 120 seconds  |  |
|                               | 7.0Adc for 10 seconds  |  |
| FIELD impedance range:        | 5Ω to 50Ω  |  |
| FIELD drive:                  | IGBT drive stage   |  |
| AUX. signal input:            | Analogue voltage input, External pot input                                   |  |
|                               | Temperature input for RTD type sensor  |  |
| BLM <sup>®</sup> function:    | BLOCK-LOAD acceptance limit setting with integrated comprehensive algorithm, |  |
| Protection functions:         | LOS  | Loss of sensing voltage protection                 |
|                               | OEX-IDMT Field   | Over Excitation protection                         |
|                               | GUV-GOV  | Generator Under / Over Voltage                     |
|                               | SVU  | Generator Voltage Unbalance                        |
|                               | GCL  | Generator Current Limit                            |
|                               | WTA-WTL  | Winding Temperature Alarm / Limit                  |
| ALARM Output:                 | 2Aac SPST N/C contact  |  |
| Communication Port:           | USB COMM port  |  |
| EMC Compliance:               | EN61000-6-2, EN61000-6-4 EN6068-1-2-14-30                                    |  |
|                               | In Progress UL94 V2 flammability safety compliance                           |  |
| Enclosure protection class:   | Electronic components protected with PU encapsulation                        |  |
| Overall dimensions:           | 142x127x58 mm  |  |
| Weight:                       | 220gr  |  |

Connection Diagram:

Mechanical Dimensions:

SYNCHRONOUS ALTERNATOR WITH AUX. WINDING

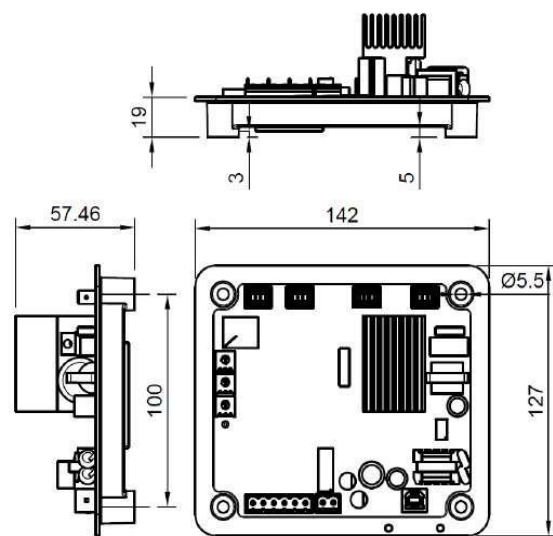
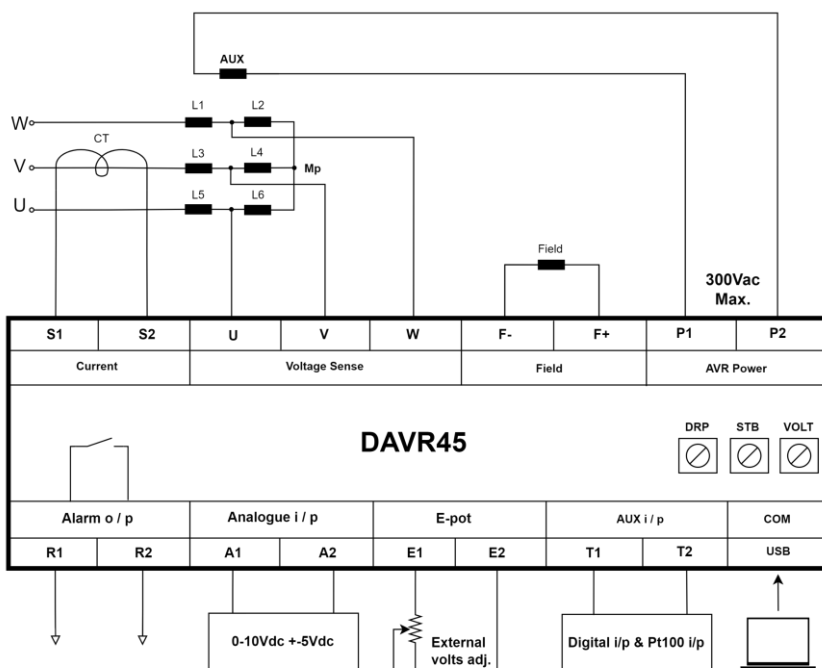

Compliance:

DAVR-45 is tested and compliant to CE regulations for emitted and conducted RFI interference, according to EN61000-6-4. Immunity is tested against EN61000-6-2. Vibration: EN60068-6-2 Dielectric strength: IEC255, Flammability: UL94, Safety: UL508

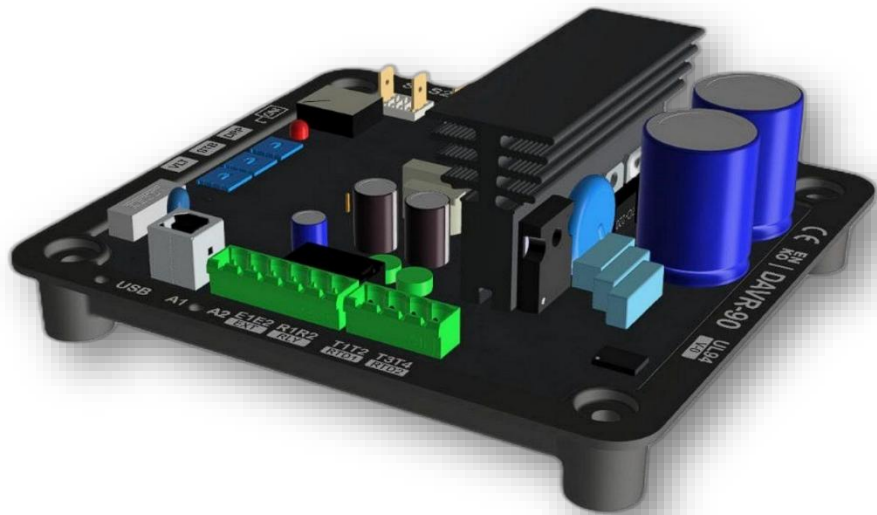
EN  
KO

# DAVR90

## Digital Voltage Regulators for Synchronous Alternators

### Product Description:

DAVR90 is a "microcontroller based, state-of-the-art design, specifically engineered for high-performance demanding applications for large capacity generator systems. This AVR is designed with complex applications in mind and gives extensive freedom to the OEM to fulfil customer requirements by configuring the AVR parameters, using PC Tools SW package.

The design is based on high-frequency PWM technique for driving the EXCITOR winding of the alternator and provides precise voltage regulation and dynamic performance, under all types of load conditions. All operation parameters are programmable, using PC Tools SW package.

DAVR90 can deliver continuous 5.0A<sub>dc</sub> Excitation power into the FIELD winding of the alternator and for limited duration, it can handle up to 10.0A<sub>dc</sub> to help smooth operation during Block-Load conditions. The drive stage design is based on IGBT technology and Excitation power is precisely controlled during dynamic load changes. PID parameters can be set to get optimum performance with all types of alternator frames.

DAVR90 has 3-phase voltage sense input and high-harmonic TRUE RMS measurement is standard in all versions. Also, power to AVR can be connected as SHUNT, AUXILIARY, or 3-phase PMG sources, depending on the type of application.

DAVR90 is designed with integrated "**Block Load Module**" (BLM<sup>®</sup>) function, which monitors the behavior of the generator by making fast FFT waveform analyses and relaxes the burden on the engine so that; engine capacity can be down-sized compared to competition on the market. This brings a big advantage when the generator is manufactured according to ISO8528 standard.

Alternator phase current is measured at high-resolution for "DROOP" compensation or LINE compensation with excellent performance. Generators running in parallel can be fine-tuned with on-board trimmer pot. Also, VOLTS and STAB values can be set with the on-board trimmers.

Alarm events can be linked to any limit of the AVR parameters, using PC Tools SW package. On-board integrated ALARM relay has SPST N/C contact, which can be controlled to trigger specific protection sequences directly from the AVR unit.

DAVR90 has two built-in RTD temperature sensor inputs, which can be used to monitor critical temperatures on the generator during operation. This feature can also be linked directly to the ALARM relay so that, if there are any excess temperature conditions, automatic load shedding sequences can be initiated via this function. This is a very useful feature, if the generator is operating under very harsh conditions.

AUX inputs on the AVR unit can be used to control the AVR voltage via external intelligent control devices and set the voltage using EXT trimming potentiometers. Both inputs can be configured via PC Tools SW package. On-board USB port is galvanically isolated so that it can be used for parameter configuration as well as monitoring.

### Main Features

- ✓ Microprocessor based design for high-performance,
- ✓ Continuous Excitation drive capability, in excess of 5A<sub>dc</sub>, 140% overload capacity for 120 sec., 200% for 10 seconds,
- ✓ Integrated BLM<sup>®</sup> function control to improve BLOCK-LOAD handling capability of the generator,
- ✓ 3-Phase TRUE RMS sense voltage measurement for precise voltage regulation in high-harmonic distorted load conditions,
- ✓ SHUNT and AUX and PMG connection modes for power input to AVR,
- ✓ AUXILIARY analogue inputs for external control of AVR functions,
- ✓ 2xPt100 temperature sensing input for alternator winding safety.
- ✓ Excellent stability control through digital signal processing,
- ✓ "LINE" compensation or "DROOP" compensation by parameter configuration setting,
- ✓ ALARM relay output for external safety sequence control of the generator,
- ✓ Galvanically isolated USB communication port for AVR parameter configuration and operation monitoring,
- ✓ Secure fast-on terminals for power connections,
- ✓ Encapsulated construction for extreme environmental operating conditions,
- ✓ Construction is resistant to high vibration mounting,
- ✓ CE compliant for EMC emissions,
- ✓ UL compliant safety standards,

| Technical Specifications      | Value   | Description   |
|-------------------------------|---|---|
| Sensing voltage range:        | 100Vac to 576Vac  | 3-phase, 2-phase or single-phase sense input connection   |
| Power connection to AVR:      | Shunt / Auxiliary/3-phase PMG   | 300Vac maximum limit                                      |
| Voltage regulation:           | <0.25%  | No-load to full load, PF>0.8 and ΔT<40°C                  |
| Voltage sensing type:         | TRUE RMS calculation, capable of operation with high harmonic loads, 3-phase sensing            |   |
| Operating frequency:          | 20Hz to 80Hz  |   |
| Operating temperature range:  | -35°C to +60°C  | 30%RH to 95%RH non-condensing                             |
| Voltage adjustment:           | On-board trimmer  | ±20% of selected voltage range                            |
|                               | External pot trimming   | ±10% of set voltage value                                 |
|                               | AUX input signal  | ±15% of set voltage value                                 |
| Current sensing:              | X/1 or X/5 Class-1 CT (on-board)  | Single-phase sensing, fitted on alternator phase-V        |
| CT burden:                    | 1VA (3VA maximum)   |   |
| Current sensing compensation: | DROOP compensation  | Reactive load compensation                                |
|                               | LINE compensation   | Load dependent line DROP compensation                     |
|                               | Motor Start Current   | Monitoring and control of motor inrush current            |
| Excitation current:           | 5.0A dc continuous  | Rated for maximum operating temperature range             |
|                               | 7.0A dc 120 seconds   |   |
|                               | 10.0A dc for 10 seconds   |   |
| FIELD impedance range:        | 5Ω to 50Ω   | 15Ω nominal winding impedance                             |
| FIELD drive:                  | IGBT drive stage  | High-frequency PWM drive stage                            |
| AUX. signal input:            | Analogue voltage input, External pot input  |   |
|                               | Temperature input for Pt100 type sensor (RTD)   |   |
| BLM* function:                | BLOCK-LOAD acceptance limit setting with integrated comprehensive algorithm,                    |   |
| Protection functions:         | LOS   | Loss of sensing voltage protection                        |
|                               | OEX   | Over Excitation protection                                |
|                               | GUV - GOV   | Generator Under / Over Voltage                            |
|                               | SVU   | Generator Voltage Unbalance                               |
|                               | GCL   | Generator Current Limit                                   |
|                               | WTA - WTL   | Winding Temperature Alarm / Limit                         |
|                               | IDMT Sense - MSF  | Motor Start Failure / Generator Current IDMT              |
|                               | RDF   | Rotating Diode Failure                                    |
| EMC Compliance:               | EN61000-6-2, EN61000-6-4 EN6068-1-2-14-30<br>In Progress UL94 V2 flammability safety compliance |   |
| ALARM Output:                 | 2.0A ac SPST N/C contact  | Configurable via PC Tools SW package                      |
| Communication Port:           | USB COMM port (isolated)  | For AVR parameter configuration and continuous monitoring |
| Enclosure protection class:   | Electronic components protected with PU encapsulation   |   |
| Overall dimensions:           | 140x155x59 mm   |   |
| Weight:                       | 310gr   |   |

## Connection Diagram:

## Mechanical Dimensions:

### SYNCHRONOUS ALTERNATOR WITH PMG

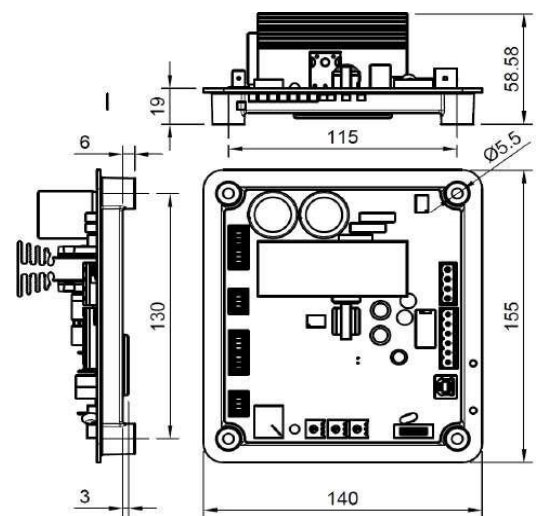
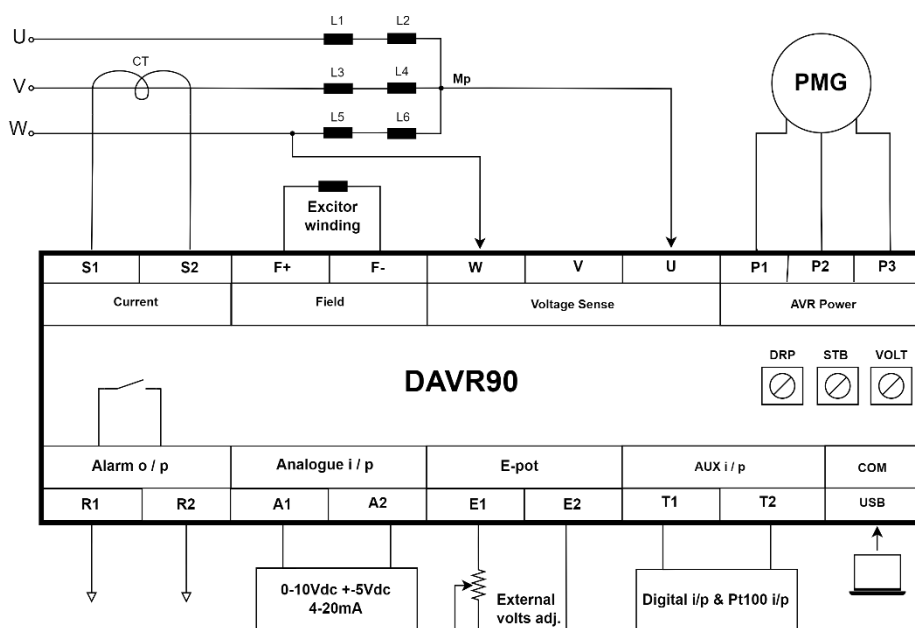

#### Compliance:

DAVR-90 is tested and compliant to CE regulations for emitted and conducted RFI interference, according to EN61000-6-4. Immunity is tested against EN61000-6-2. Vibration: EN60068-6-2. Dielectric strength: IEC255, Flammability: UL94, Safety: UL508

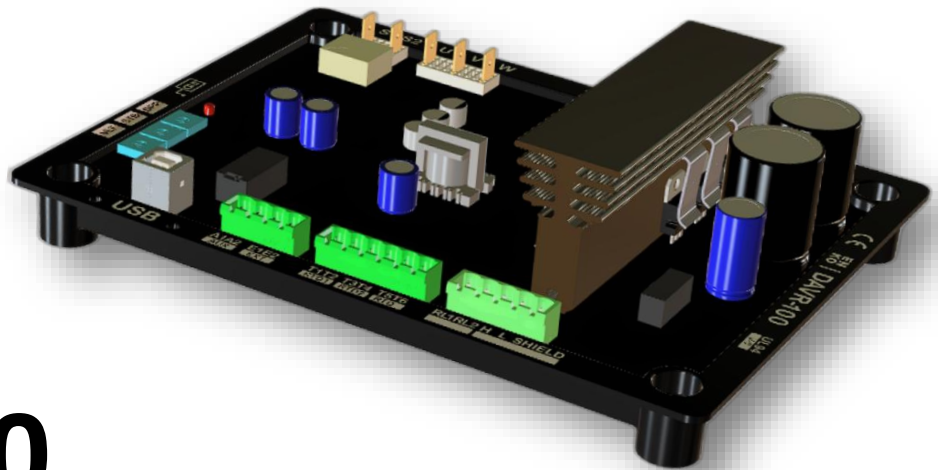
EN  
KO

# DAVR100

## Digital Voltage Regulators for Synchronous Alternators

### Product Description:

DAVR100 is designed for high-performance applications, fulfilling a wide range of requirements for both stand-alone applications as well as parallel running generator groups for high-power generation.

It is based on a high-capacity signal processing microcontroller design architecture, integrated with intelligent IGBT power drive stage for alternator excitation. There are various optional features, where the customer can select for their specific application. The AVR unit is equipped with comprehensive communication capabilities, which can be interfaced to peripheral intelligent control devices for complex operations. All COM ports are galvanically isolated for safe network connection.

Excitation drive is designed to deliver high-power even during stator short circuit conditions, with an ample 15.0A<sub>dc</sub> current for 10 seconds. Continuous excitation power at maximum temperature can exceed 7.0A<sub>dc</sub>. The EXCITATION current is monitored precisely for protection against alternator faults. The AVR can be connected in SHUNT or AUX mode, as well as connection to 3-phase PMG power source.

Voltage regulation is based on synthesised measurement of the 3-phase sense inputs and high sampling frequency enables high harmonic waveform analyses, which can perform better than 0.25% accuracy even with highly distorted load conditions. All PID parameters are monitored and set with an intelligent algorithm for stable operation under all load conditions and at the same time optimum performance is delivered at high block load switching, minimising the voltage fluctuations.

DAVR100 is designed with integrated “**Block Load Module**” (BLM<sup>®</sup>) function, which monitors the behavior of the generator by making fast FFT waveform analyses and relaxes the burden on the engine so that; engine capacity can be down-sized compared to competition on the market. This brings a big advantage when the generator is manufactured according to ISO8528 standard.

Alternator phase current is measured at high-resolution for “DROOP” compensation or LINE compensation with excellent performance. Also, with MOTOR START function, it can control the field excitation for starting high power AC motors without tripping the protection devices.

Alarm events can be linked to any limit of the AVR parameters, using PC Tools SW package. On-board integrated ALARM relay has SPST N/C contact, which can be controlled to trigger specific protection sequences directly from the AVR unit.

DAVR100 has three built-in RTD temperature sensor inputs, which can be used to monitor critical temperatures on the generator during operation. This feature can also be linked directly to the ALARM relay so that, if there are any excess temperature conditions, automatic load shedding sequences can be initiated via this function. This is a very useful feature, if the generator is operating under very harsh conditions.

#### Main Features

- ✓ High-performance signal processor-based design,
- ✓ Continuous Excitation drive capability, in excess of 7.0A<sub>dc</sub>, 150% overload capacity for 120 sec., 220% for 10 seconds,
- ✓ Measurement of FIELD current for effective OEX protection function,
- ✓ Integrated BLM<sup>®</sup> function control to improve BLOCK-LOAD handling capability of the generator,
- ✓ 3-Phase TRUE RMS sense voltage measurement for precise voltage regulation in high-harmonic distorted load conditions,
- ✓ SHUNT, AUX and PMG connection modes for power input to AVR,
- ✓ AUXILIARY analogue inputs for external control of AVR functions,
- ✓ 3xPt100 temperature sensing input for alternator winding safety.
- ✓ Excellent stability control through digital signal processing,
- ✓ “LINE” compensation or “DROOP” compensation by parameter configuration setting,
- ✓ Stator current and motor current measurement and protection,
- ✓ ALARM relay output for external safety sequence control of the generator,
- ✓ Galvanically isolated USB and CAN BUS communication ports for AVR parameter configuration and integration to system network,
- ✓ Encapsulated construction for extreme environmental operating conditions,
- ✓ Construction is resistant to high vibration mounting,
- ✓ CE compliant for EMC emissions,
- ✓ UL compliant safety standards,

| Technical Specifications      | Value   | Description  |
|-------------------------------|---|--|
| Sensing voltage range:        | 100Vac to 576Vac  | 3-phase, 2-phase, or single-phase sense input connection |
| Power connection to AVR:      | Shunt / Auxiliary/3-phase PMG   | 300Vac maximum limit                                     |
| Voltage regulation:           | <0.25%  | No-load to full load, PF>0.8 and ΔT<40°C                 |
| Voltage sensing type:         | TRUE RMS calculation, capable of operation with high harmonic loads, 3-phase sensing            |  |
| Operating frequency:          | 20Hz to 80Hz  |  |
| Operating temperature range:  | -35°C to +60°C  | 30%RH to 95%RH non-condensing                            |
| Voltage adjustment:           | On-board trimmer  | ±20% of selected voltage range                           |
|                               | External pot trimming   | ±10% of set voltage value                                |
|                               | AUX input signal  | ±15% of set voltage value                                |
| Current sensing:              | X/1 or X/5 Class-1 CT (on-board)  | Single-phase sensing, fitted on alternator phase-V       |
| CT burden:                    | 1VA (3VA maximum)   |  |
| Current sensing compensation: | DROOP compensation  | Reactive load compensation                               |
|                               | LINE compensation   | Load dependent line DROP compensation                    |
|                               | Motor Start Current   | Monitoring and control of motor inrush current           |
| Excitation current:           | 7.0A dc continuous  | Rated for maximum operating temperature range            |
|                               | 10.0A dc 120 seconds  |  |
|                               | 15.0A dc for 10 seconds   |  |
| FIELD impedance range:        | 5Ω to 50Ω   | 15Ω nominal winding impedance                            |
| FIELD drive:                  | IGBT drive stage  | High-frequency PWM drive stage                           |
| AUX. signal input:            | Analogue voltage input, External pot input<br>3 x Temperature input for Pt100 type sensor (RTD) |  |
| BLM <sup>®</sup> function:    | BLOCK-LOAD acceptance limit setting with integrated comprehensive algorithm,                    |  |
| Protection functions:         | LOS   | Loss of sensing voltage protection                       |
|                               | OEX   | Over Excitation protection                               |
|                               | GUV - GOV   | Generator Under / Over Voltage                           |
|                               | SVU   | Generator Voltage Unbalance                              |
|                               | GCL   | Generator Current Limit                                  |
|                               | WTA - WTL   | Winding Temperature Alarm / Limit                        |
|                               | IDMT Sense - MSF  | Motor Start Failure / Generator Current IDMT             |
| RDF                           | Rotating Diode Failure  |  |
| ALARM Output:                 | 2.0A ac SPST N/C contact  | Configurable via PC Tools SW package                     |
| Communication Ports:          | USB COMM port (isolated)  | For AVR parameter configuration                          |
|                               | CAN J1939 (isolated) (AMF-L Connection is also possible)  | For system network connection and monitoring             |
| EMC Compliance:               | EN61000-6-2/4 EN6068-1-2-14-30<br>In Progress UL94 V2 flammability safety compliance            |  |
| Enclosure protection class:   | Component protection to IP65, Terminal protection to IP00                                       |  |
| Overall dimensions:           | 155x205x59 mm   |  |
| Weight:                       | 340gr   |  |

## Connection Diagram:

## Mechanical Dimensions:

### SYNCHRONOUS ALTERNATOR WITH PMG

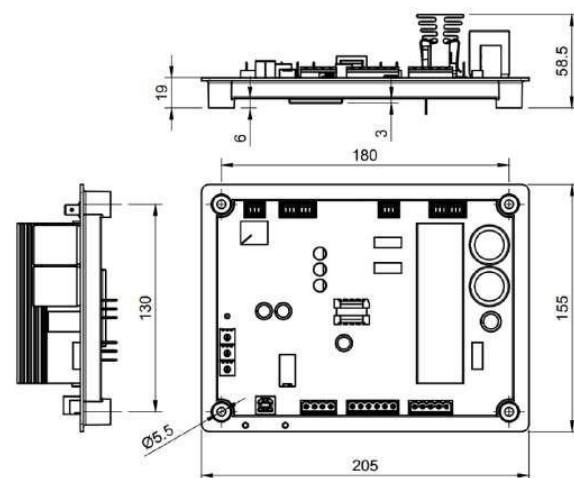
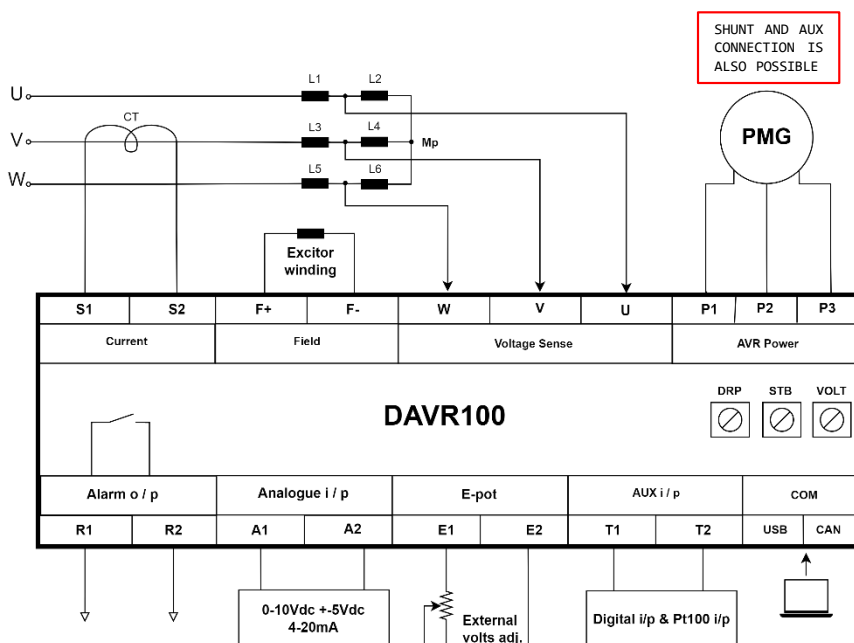

#### Compliance:

DAVR-100 is tested and compliant to CE regulations for emitted and conducted RFI interference, according to EN61000-6-2. Immunity is tested against EN61000-6-4. Vibration: EN60068-6-2 Dielectric strength: IEC255, Flammability: UL94, Safety: UL508